

PHILLIPS EXETER ACADEMY

2026-27

Courses of Instruction





OUR MISSION

Unite goodness and knowledge and inspire youth from every quarter to lead purposeful lives

OUR VALUES

Knowledge and Goodness

“Above all, it is expected that the attention of instructors to the disposition of the minds and morals of the youth under their charge will exceed every other care; well considering that though goodness without knowledge is weak and feeble, yet knowledge without goodness is dangerous, and that both united form the noblest character, and lay the surest foundation of usefulness to [hu]mankind.” Exeter today continues the commitment to unite knowledge and goodness. The challenges that students meet at Exeter and the support they receive have a common objective: to stimulate their development as individuals and prepare them to lead purposeful lives.

Academic Excellence

Academic excellence is a signature strength of Phillips Exeter Academy. In every discipline and at every level within our curriculum we inspire students to develop critical thinking skills and seek complex truths. Intellectual exploration through rigorous inquiry and thoughtful discourse at the Harkness table nurtures inquisitiveness, creativity, insight, empathy, independent thought and mastery in our students.

Youth From Every Quarter

“The Academy shall ever be equally open to youth of requisite qualification from every quarter.” We seek to build an intentionally diverse community of students and adults. We are committed to teaching the skills, modeling the behaviors, providing the resources, and cultivating the inclusion and equity that are required to unlock the richness of that diversity. Our Harkness pedagogy is grounded in the belief that we are all better equipped to learn and to lead when our thoughts are tested by others, particularly by those whose ideas, perspectives, experiences or identities differ from our own.

Youth Is the Important Period

The “time of youth is the important period” to instill a lasting capacity to nurture one’s self, develop a sense of one’s own potential and consider one’s place in the larger whole. Our residential community encourages students to explore emerging interests — academic, artistic, athletic and extracurricular — with similarly motivated peers and in the process develop their values and passions and the agency needed to carry these forward.

Non Sibi

Non Sibi, or Not For Oneself, inscribed on Exeter’s seal, attests to the philosophy that wisdom gained here should be used for others as well as for oneself. Exonians are motivated by this philosophy to face the challenges of their day. Teaching and living the principles of a just and sustainable society — environmentally, economically and socially — are fundamental to this philosophy today. Exeter seeks to graduate young people whose ambitions and actions are inspired by their interest in others and the world around them.

In the values above, text in quotations is taken from the Academy’s Deed of Gift (1781).

2026-27

Courses of Instruction

Table of Contents

ACADEMIC PROGRAM	1	MODERN LANGUAGES AND CULTURES	41
		MUSIC	50
DESIGNING YOUR COURSE OF STUDY	1	PHYSICAL EDUCATION AND ATHLETICS	54
GENERAL GUIDELINES		PSYCHOLOGY	58
GUIDELINES BY CLASS		RELIGION, ETHICS AND PHILOSOPHY	58
		SCIENCE	64
DIPLOMA REQUIREMENTS	2	THEATER AND DANCE	70
FOR FOUR-YEAR STUDENTS		TRANSITION COURSES	73
FOR THREE-YEAR STUDENTS			
FOR TWO-YEAR STUDENTS		SPECIAL ON-CAMPUS OFFERINGS	74
FOR ONE-YEAR STUDENTS		FIELD COURSES	
		SENIOR PROJECTS	
MEETING DIPLOMA REQUIREMENTS	3	SPECIAL OFF-CAMPUS OFFERINGS	75
GRADING		FALL OR SPRING TERM AT THE	
A NOTE ABOUT COURSE NUMBERS		MOUNTAIN SCHOOL, VERSHIRE, VERMONT	
AND DESCRIPTIONS		SCHOOL YEAR ABROAD	
		FALL TERM AT THE ISLAND SCHOOL,	
COURSE OFFERINGS		CAPE ELEUTHERA, BAHAMAS	
ANTHROPOLOGY	5	FALL TERM IN GRENOBLE, FRANCE	
ART	5	FALL TERM IN YOKOHAMA, JAPAN	
CLASSICAL LANGUAGES	8	WINTER TERM IN GÖTTINGEN, GERMANY	
COMPUTER SCIENCE	13	WINTER TERM IN MADRID, SPAIN	
ECONOMICS	15	SPRING TERM WASHINGTON INTERN PROGRAM	
ENGLISH	16		
HEALTH AND HUMAN DEVELOPMENT	23	ADVANCED PLACEMENT PROGRAM	77
HISTORY	25		
INTEGRATED STUDIES	32	NCAA AND ENGLISH REQUIREMENTS	78
MATHEMATICS	36		

Contents dated April 7, 2026. Updated information
can be viewed online at exeter.edu/academics.



Academic Program

Phillips Exeter Academy prepares students for a lifetime of learning. Our four-year college preparatory program accepts students for admission in each of the four high school classes. Exeter also admits a select number of high school graduates seeking an unmatched experience in one year of postgraduate study.

Exeter's curriculum and diploma requirements seek to balance breadth of exposure and in-depth pursuit of a student's strongest interests. All students who attend the school for more than one year will experience coursework in seven different academic areas.

Designing Your Course of Study

When selecting their individual educational program, newly accepted students should refer to the course selection information for new families on our website, www.exeter.edu/newfamilies. Any questions can be directed to the Dean of Academic Affairs or the Scheduler. Each April, all current 9th, 10th and 11th graders consult with their advisers to plan their programs of study for the following year. Whatever their grade level, students take courses as warranted by placement examination results and/or previous coursework. Newly admitted students may write placement examinations at home. If it seems advisable, a student's placement may be adjusted during the term. The Academy makes every effort to meet students' and parents' requests for programs of study, but it reserves the right to place students in courses according to the judgment of the Dean of Students Office, in consultation with the department chairs.

Due to the complicated nature of the scheduling process, requests for specific schedules or free formats will not be granted. The number of students in any course may be limited; any announced course for which the enrollment is deemed insufficient may be withdrawn.

General Guidelines for Designing Your Course of Study

All students must take five one-credit academic courses and a physical education course each term, totaling six credits per term and 18 credits per year. Exceptions are limited to the following:

- Students will earn an additional 1/3 credit for each required Health and Human Development (HHD) course.
- Students enrolled in some applied music, theater and dance courses are eligible to earn up to an additional 2/3 credit for those courses in any given term.
- **Credit Option:** Students enrolled in any partial-credit course may choose to "credit opt" in the term in which they will accumulate a full credit in that discipline, thereby reducing their course load in that term. In the case of music, the partial credits must be accumulated in consecutive terms in the same instrument or ensemble. Students must consult with their advisers and the Dean of Academic Affairs to utilize this option. Credit Options do not appear on the transcript. Students may not select the Credit Option and the HHD Option in the same term.
- **HHD Option:** Two-year, three-year and four-year students are required to pass three 1/3 credit courses in Health and Human Development in order to meet diploma requirements. These students may use this one credit to reduce their course load in any term, provided they do so by the week following the midterm reporting period. Students must consult with their adviser and the Dean of Academic Affairs to utilize this option. HHD Options do not appear on the transcript. Students may not select the Credit Option and the HHD Option in the same term.

Note: Students who utilize the Credit Option or the HHD Option in order to take only a four-course load in a term must understand that doing so could have negative consequences in their college application process.

- Students may decide to drop physical education (in exchange for a free format) for one term in each of the 10th-, 11th- and 12th-grade years by registering for Choice Format, CHF001, before the deadline in the preceding term.

Any further exceptions must be approved by the faculty.

Guidelines for Course Design, by Class

9th Grade: Ninth graders ordinarily take English 100, 210 and 220, mathematics, a modern or classical language, biology or physics, and health and human development. They also take one elective each term, generally chosen from art; computer science; history; music; religion, ethics and philosophy; or theater and dance. It is recommended that students select a 200-level history course as one of these electives.

10th Grade (Lower): Lowers ordinarily take English 310, 320 and 330, mathematics, a modern or classical language, science, and health and human development. They also take one elective each term. Most lowers take a 300-level history course in order to satisfy the prerequisite for U.S. History.

11th Grade (Upper): Uppers must take English 410, 420 and 430 and health and human development. In addition, they take other courses that fulfill diploma requirements and their interests. Most students take U.S. History in the 11th-grade year.

12th Grade (Senior): Seniors must take two terms of English at the 500 level and health and human development. Seniors design academic programs in consultation with their advisers and the College Counseling Office. Attention should be paid to completing diploma requirements as well as the desired breadth and depth of study.

Note: Students should not enroll in a course taken at a previous high school without permission from the department chair.

Diploma Requirements

Diploma Requirements for Four-Year Students

ARTS: Three term credits. Two terms must be in studio and/or performance courses. Term credits must be in at least two departments from among art, music, or theater and dance.

CLASSICAL AND MODERN LANGUAGES: Nine term credits in the same language, or pass Language 400 or higher. *In Latin or Greek, students must earn nine term credits or pass LAT400, LAT531 or GRK531.*

COMPUTER SCIENCE: One term credit.

ENGLISH: Eleven term credits. Students must complete the sequence 100, 210, 220, 310, 320, 330, 410, 420, 430 and 500, in addition to one term credit at the 500 level in the 12th-grade year.

HEALTH AND HUMAN DEVELOPMENT: Five 1/3 credit courses, earned through completion of HHD 110, 120, 240, 340 and 490.

HISTORY: Six term credits: one 200-level course, one 300-level course and three 400-level courses. The sixth course may be at any level; however, the courses taken must include at least one of the following: 200, 202, 205, 206, 208, 305, 307, 308, 309, 310, 502, 556, 558, 560, 565, 566, 567, 577, 586 and 587.

MATHEMATICS: Nine term credits, or pass a mathematics course numbered 330 or higher.

PHYSICAL EDUCATION: Nine term credits, including three terms of the 9th-Grade Physical Education Program. One term on a varsity or junior varsity team is equivalent to one term of 9th-grade physical education. Students may elect to take either two or three terms of physical education or athletics in each of the 10th-, 11th and 12th-grade years. Students who choose to participate in physical education/athletics for only two terms must enroll in Choice Format (CHF001) for the third term.

RELIGION, ETHICS AND PHILOSOPHY: Two term credits.

SCIENCE: Six term credits: three term credits of biology and either three term credits of chemistry or three term credits of physics. For most students this will mean taking an introductory biology sequence and either an introductory chemistry or an introductory physics sequence.

Diploma Requirements for Three-Year Students

ARTS: Two term credits from art, dance, music or theater. One term must be in a studio or performance course.

CLASSICAL AND MODERN LANGUAGES: Seven term credits in the same language, or pass Language 400 or higher. *In Latin or Greek, students must earn seven term credits or pass LAT400, LAT531 or GRK531.*

ENGLISH: Eight term credits. Students must complete the sequence 310, 320, 330, 410, 420, 430 and 500, in addition to one term credit at the 500 level in the 12th-grade year.

HEALTH AND HUMAN DEVELOPMENT: Four 1/3 credit courses, earned through completion of HHD 210, 240, 340 and 490.

HISTORY: Five term credits: one 300-level course and three 400-level courses. The fifth course may be at any level; however, the courses taken must include at least one of the following: 200, 202, 205, 206, 208, 305, 307, 308, 309, 310, 502, 556, 558, 560, 565, 566, 567, 577, 586 and 587.

If an approved U.S. history course has been taken in grade 10 at another school, then five term credits, at least one of which comes from the above list. Please consult with the History Department chair concerning the waiver and course selection.

MATHEMATICS: Seven term credits, or pass a mathematics course numbered 330 or higher.

PHYSICAL EDUCATION: Six terms. Students may elect to take either two or three terms of physical education or athletics in each of the 10th-, 11th and 12th-grade years. Students who choose to

participate in physical education/athletics for only two terms must enroll in Choice Format (CHF001) for the third term.

RELIGION, ETHICS AND PHILOSOPHY: One term credit.

SCIENCE: Five term credits.

- › For students who have not satisfactorily completed a full-year laboratory course in biology, chemistry or physics at a previous secondary school: three term credits of biology and two credits of either physics or chemistry, OR three term credits of either physics or chemistry and two term credits of biology.
- › For students who have satisfactorily completed a full-year laboratory course in either physics or chemistry at a previous secondary school: three term credits of biology and two term credits of physics, chemistry or Earth and planetary science.
- › For students who have satisfactorily completed a full-year laboratory course in biology at a previous secondary school: three term credits of either chemistry or physics and two additional term credits of science.
- › For students who have satisfactorily completed a full-year laboratory course in biology and a full-year laboratory course in either physics or chemistry at a previous secondary school: five term credits of science.

Diploma Requirements for Two-Year Students

ARTS: Two term credits from art, dance, music or theater. One term must be in a studio or performance course.

CLASSICAL AND MODERN LANGUAGES: Four term credits in the same language, or pass Language 400 or higher. In Latin or Greek, students must earn four term credits or pass LAT400, LAT531 or GRK531.

ENGLISH: Five term credits. Students must complete the sequence 410, 420, 430 and 500, in addition to one term credit at the 500 level in the 12th-grade year.

HEALTH AND HUMAN DEVELOPMENT: Three 1/3 credit courses, earned through completion of HHD 310, 340 and 490.

HISTORY: Three term credits at the 400-level for those who have not taken U.S. history at another school in grades 10 or 11. Otherwise, three term credits of 300-, 500- or 600-level courses (in consultation with the History Department chair).

MATHEMATICS: Four term credits, or pass a mathematics course numbered 330 or higher.

PHYSICAL EDUCATION: Four terms. Students may elect to take either two or three terms of physical education or athletics

in each of the 11th- and 12th-grade years. Students who choose to participate in physical education/athletics for only two terms must enroll in Choice Format (CHF001) for the third term.

RELIGION, ETHICS AND PHILOSOPHY: One term credit.

SCIENCE: Three term credits. Students who have not satisfactorily completed a full-year laboratory course in both biology and in either physics or chemistry must elect the science (biology or physics/chemistry) that they have not studied at a previous secondary school.

Diploma Requirements for One-Year Students

One-year seniors (including postgraduates) design individual academic programs with advisers in consultation with the offices of the Dean of Students and College Counseling, and with department chairs. The programs will reflect consideration of the subjects studied at previous secondary schools, college admission requirements, and the desirable breadth and depth of study called for in Exeter's four-year program.

ENGLISH: ENG500, in addition to one term credit at the 500 level.

HEALTH AND HUMAN DEVELOPMENT: Two 1/3 credit courses, earned through completion of HHD410 and HHD490.

HISTORY: Students who enter the Academy without credit for one year of U.S. history taken in grades 10, 11 or 12 are required to take three term credits at the 400-level.

PHYSICAL EDUCATION: Students may elect to take either two or three terms of physical education or athletics. Students who choose to participate in physical education/athletics for only two terms must enroll in Choice Format (CHF001) for the third term.

Meeting Diploma Requirements

A student earns one **term credit** for any course passed. Partial term credits are awarded in health and human development, and some applied music, theater and dance courses.

A student earns one **diploma credit** for passing a course that fulfills a diploma requirement.

To receive a diploma, all students must:

- › Have attendance on the Exeter campus for at least three terms during the 11th- and 12th-grade years.
- › Be free from any disciplinary action, official or pending.
- › Accumulate term credits according to the following table. Credits are awarded only for courses passed at Exeter.

ENTERING GRADE (SEPTEMBER)	TERM CREDITS REQUIRED	PE CREDITS REQUIRED	TOTAL
9	54	9	63
10	41	6	47
11	27	4	31
12 (including PG)	13	2	15

Students may repeat a failed course only once. A student receiving a failing grade (an E) has the option of repeating the course if it is available in any subsequent term. Upon successful completion, the repeated course earns term credit and diploma credit where applicable. Both grades are recorded on the academic transcript and are included in the student's GPA.

Students who fail a term of study in a sequential discipline will not receive term credit, nor diploma credit, for that course, except under the following condition:

- › If a student taking a course in a sequential discipline fails the course or receives no credit for the course, and that same course is not offered in the following term, then the department, after consulting with the Dean of Academic Affairs, may allow the student to take the next course in the sequence. The individual department, after consulting with the Dean of Academic Affairs, may grant diploma credit for the failed course (or the course that received no credit) upon the student's successful completion of the next course in that sequence; however, this credit would not count toward the minimum number of required term credits listed in the table above.

A student receiving any D grade has the option of repeating the course once, if it is available in any subsequent term. A student receiving any grade may request to repeat a course by contacting the chair of the department in which the course was taken. The request will be considered by the department and, if approved by the department, by the Academic Advising Committee. The repeated course counts toward the five-course-per-term requirement but does not earn an additional diploma credit. Both grades are recorded on the academic transcript and are included in the student's GPA.

The Classical Diploma Latin Concentration is awarded to students who successfully complete either Latin 530 or 611 and Greek 431. The Classical Diploma Greek Concentration is awarded to students who successfully complete Greek 611 and either Latin 220 or 431.

Students whose native language is not English will be placed at the proper level in English by the English Department. In order to meet diploma requirements, students must continue taking English courses in sequence until graduation. Students who enter the Academy without credit for one year of U.S. history taken in grade 10, 11 or 12 are required by law to take it at Exeter.

Grading

Excepting the fall term of ninth grade, academic work is graded on an 11-point scale in which A=11, A-=10, etc., to E=0. The minimum passing grade is D-. A squared grade (e.g., C²) indicates unsatisfactory effort. For the fall term of ninth grade, all courses will be recorded as either pass (P) or no pass (NP).

A Note About Course Numbers and Descriptions

The first digit of the course number corresponds to the "level" of the course:

- › 100s: Preparatory level
- › 200s: Intermediate/Advanced level
- › 300s: Advanced proficiency level
- › 400s: Beyond AP or first-year college level
- › 500s: First- or second-year college level
- › 600s/700s: College major equivalency
- › 999: Independent field course or tutorial

Unless otherwise indicated in the description, a course:

- › Has no prerequisite,
- › Is open to members of all classes,
- › Is offered each term,
- › Does not meet during the reserve format.

Course information is subject to change. For updates, please check www.exeter.edu/academics.

COURSE OFFERINGS

Anthropology

Anthropology combines the approaches of both the biological and social sciences. Its focus is on human beings as members of the animal kingdom as well as members of a society. Anthropologists do not limit themselves to any particular group of people or to any one period of history. Anthropologists place emphasis on comparative studies and attempt to isolate and define laws or principles that govern the formation and development of human societies and cultures.

ANT500: CULTURAL ANTHROPOLOGY: EXPLORING HUMAN BEHAVIOR AND MEANING

Anthropologists study humans as both biological and cultural creatures. This scholarly orientation raises many fascinating questions. To what degree does culture shape our actions and

ideas? Are we primarily products of biological nature or cultural nurture? Can cultural norms make rational people act irrationally? Are there universal human rights or do cultures dictate what we think is ethical? These debates are critical for understanding human interaction and have significant application in fields ranging from law to medicine. Among the topics considered are: “the mind” and epistemology; discipline, law and rules; human bodies and communication; social taboos; ritual patterns of meaning; notions of cleanliness and defilement; festivals; and mythology. These elements of cultural life will be explored in social settings spanning the globe, but also within our own community at Phillips Exeter Academy. Much of the course attempts to contextualize 20th-century anthropological methods against the foil of postmodern critiques. *Open to 10th, 11th and 12th graders. Offered: winter term.*

Art

The Art Department at Exeter provides exciting, professional and rigorous studio experiences that explore a variety of art mediums in state-of-the-art studios in the Frederick R. Mayer Art Center. Studio courses emphasize a strong blend of technical skills and creative analysis that fosters teamwork, stylistic growth and experimentation. Our studio program is committed to creating safe and welcoming spaces. Justice, diversity, equity and inclusion are paramount to our studio practices and woven into our curriculum. Innovation and technology are connected to traditional studio processes and techniques in sophisticated, contemporary practices. The Exeter art faculty is composed of practicing artists, each with specialties in particular disciplines.

This paradigm cultivates a creative environment where students make personal discoveries that are pivotal in their intellectual development. Student artwork is exhibited in various venues on campus. Each spring, a vibrant selection of advanced student work is on view and celebrated in the Lamont Gallery.

The Michael Clark Rockefeller '56 Memorial Visiting Artists Fund provides opportunities for Exeter art students to interact with significant contemporary artists and create unique works. Visiting artists offer hands-on demonstrations and class visits

and engaging slide talks for the Exeter community.

All studio courses provide credit toward the studio arts requirement. Students are required to take the appropriate prerequisites for 400-, 500- and 600-level studio classes. If students have extensive experience and skill, it is recommended that they apply for an art review via the department chair. If the Art Department grants approval, they will be placed on an accelerated track in one of the 400-level classes.

If students are interested in pursuing the Art Department sequence by progressing to the next level in particular classes, they are encouraged to plan ahead to ensure enrollment.

In 200-level art classes, students focus on honing and understanding technical skills that lay a foundation for more advanced skills in 400-level courses. Assignment prompts are open-ended in the 200 levels, and themes like identity and childhood nostalgia are explored. In 400-level classes, teachers encourage students to focus on individual concept development, to develop their styles, and to work toward refining advanced skills. Students are also encouraged to try new techniques, write artist statements and title their pieces, and participate in an end-of-term art exhibition.

In the Art 500 and 690 courses, students continue to explore recurring themes in their work and have autonomy over their creative processes with their own studio practices. This will help students build a portfolio for college applications and learn how to create a professional exhibition, work with a gallery, and design publications for advertising their work.

ART202: CERAMICS I: FORM + FUNCTION

The Exeter Clay Studio introduces students to methods used to create unique sculpture and tableware. Developing their creative concepts, students will throw on the potter's wheel, hand-build forms, and create a series of pieces over the course of the term, which may include objects such as plates, cups, bowls, vessels and sculpture. Drawing inspiration from contemporary ceramic artists, the class will explore a variety of techniques for surface design, glazing, and firing. The teacher will offer innovative and sophisticated approaches that will provide further opportunities for experimentation.

ART203: 3-D DESIGN: FORM + SPACE

This course offers innovative, hands-on studio projects in three-dimensional design through an interdisciplinary approach that spans architecture, industrial design, fashion and apparel. Students explore the relationship between form and function through concept visualization, process sketching, preliminary models and patterns, and product prototyping, which serve as foundational components of each studio project. Emphasis is placed on creative problem-solving, experimentation and thoughtful design development. Students learn a wide range of three-dimensional rendering and construction techniques while creating functional and sculptural artworks using diverse tools and materials. These include sewing tools (for sewing by hand), hand-building tools, cardboard, fabric, wire, metal, found objects, plastic and wood. Projects encourage students to work across disciplines, combining structural and textile-based methods. The course also encourages collaboration, allowing students to work with the Design Lab to access tools such as laser cutters, 3D printers and other fabrication equipment when appropriate. Sustainability is a key focus throughout the course, with projects emphasizing recycled and repurposed materials and thoughtful consideration of material life cycles. Students are encouraged to explore personal interests, cultural identity and everyday experiences through three-dimensional form. Throughout the term, students maintain process sketchbooks to document research, experimentation and creative development. The course concludes with a final critique and presentation of completed works, fostering reflection, dialogue and shared learning.

ART205: PHOTOGRAPHY I: COMPOSING CONCEPTS

This course allows students to channel their excitement and passion for photography into a more intentional and sophisticated image-making process. Using digital cameras, students will gain a functional understanding of essential camera skills and photographic principles, including maintaining proper exposure and

working with lighting in the photo studio using professional lights. Students will acquire skills in digital workflow in the photo lab using Lightroom Classic and Photoshop techniques and inkjet printing methods, including large-format printing. Students will also develop their critique skills through ongoing discussions. Throughout the term, student photographers develop a vibrant portfolio based on a series of thematic photo explorations, which break down the elements inherent to every photograph, such as vantage point, the frame, time and color. These projects challenge students to think conceptually, to shoot creatively, to develop an eye for strong composition and quality of light, and to make images that start conversations.

ART206: PRINTMAKING I: POP CULTURE

The printmaking course is a comprehensive studio experience that emphasizes experimentation and creativity while providing a strong technical basis. Students explore a variety of print processes, including screen printing, block carving, and monotype and letterpress printing. Using surfaces such as linoleum, woodblocks and silk screens, combined with a wide variety of carving tools and inks, students will create a substantial print portfolio that explores such concepts as image reversal, multiplicity, color theory, commercial applications and graphic design. Inspiration for projects includes fonts, portraits, still-life objects, photographs, media references and works by contemporary artists. Inventive approaches, including T-shirt printing, will also be explored.

ART208: PROJECTS IN DRAWING + PAINTING

In this comprehensive studio course, students explore the fluid relationship between drawing and painting. Studio projects prompt the exploration of art fundamentals common to both studio mediums, including line, shape, form, space, tonality, color theory and composition. As students grow technically and conceptually, they are encouraged to be experimental and creative in rendering still life objects using graphite and water-mixable oil paint. Students are taught surface preparation, including the construction of hand-stretched canvases. Students employ a variety of mark-making techniques to thoughtfully record ideas and visual perceptions. The understanding of art as a communication tool and expressive universal language is continuously explored and central to the course. Studio projects place a strong emphasis on process, including the usefulness of preliminary sketches, compositional studies, underpaintings, color recipes and critical analysis of works in progress. Dynamic sketchbook assignments enhance ongoing studio projects. Relevant examples of contemporary art provide a valuable seasoning with the opportunity to make stylistic connections to significant artists and enrich their own works.

ART402: ADVANCED CERAMICS: MOLDING MEANING

This advanced course offers a combination of assigned and self-directed projects with a further investigation of working with clay. Building off of skills gained in Ceramics I, students develop a more sophisticated approach to methods and techniques that are used to create. Projects such as throwing, hand-building and

sculpting foster individual style and creativity. Students will focus on the process and exploration of a broad range of contemporary clay works, functional, industrial and sculptural. Examples of contemporary artists' pottery and sculpture are used as inspiration for studio assignments. Advanced Ceramics also offers the unique opportunity to study the science and chemistry behind glazing and firing. *Prerequisite: ART202. Offered: fall and winter terms.*

ART403: ADVANCED PROJECTS IN 3D DESIGN

This course offers the opportunity to further investigate 3-D studio projects in industrial and apparel design, product prototypes and sculptural models. Students pursue a self-directed intensive that explores a specific theme or topic, thoughtfully informed by in-depth critiques, professional explorations and functional design forms, and culminating in a final pop-up exhibit. Throughout the term, a strong emphasis is placed on process and personal vision, and students serve as peer critics, working side-by-side as part of a design team. The relationship between form and function and the visualization of concepts are fundamental. Process sketches, preliminary models and patterns, notebooks, aesthetic emphasis, creativity, and independent goal setting are vital to the strength of the final products. Students learn entrepreneurial skills and teamwork in an energetic, rigorous studio atmosphere. *Prerequisite: ART203. Offered: winter and spring terms.*

ART405: ADVANCED PHOTOGRAPHY: BEYOND THE CAMERA

Advanced Photography is designed to challenge students to go beyond technical skills and photographic principles to establish a conceptually strong personal artistic voice. Through hands-on practice, in-depth critique and three main projects, students will develop a refined, concept-driven, professional portfolio. In the studio they will also examine lighting techniques that cover a wide range of potential uses, centered around the portrait and the still life, while out-of-studio assignments will become increasingly more in-depth and creatively challenging. A range of tools will be used, including software, inkjet printers and LED studio lighting equipment. Students will produce original work, with special attention to ways in which their technical and aesthetic decisions can clarify their artistic intentions. Photoshop and Lightroom Classic are used to explore creative and experimental possibilities for enhancing and manipulating digital photos and video. The course culminates with a self-directed final project with a written artist statement, allowing students to practice proposal writing, project development and final presentation, while pursuing work rooted in their own interests and experiences. *Prerequisite: ART205. Offered: fall and winter terms.*

ART406: ADVANCED PRINTMAKING: LIMITED EDITIONS

This advanced printmaking course provides the opportunity to pursue individual studio projects using a range of media, inks and printing surfaces. Students develop a series of prints that revolve around a chosen concept using one or more printing processes that demonstrate a level of expertise. Class critiques will enhance

the production of a portfolio of prints with a strong emphasis on experimentation, technical skill, conceptual strength, and aesthetic style. Each term, the class works collaboratively as a design team to create a limited-edition printed item and a final pop-up show of selected prints from the term. *Prerequisite: ART206. Offered: fall and spring terms.*

ART408: ADVANCED PROJECTS: PAINTING PORTRAITS

This 2-D studio intensive provides the exciting opportunity to pursue more individualized works on paper, hand-stretched canvas and other surface options with a focus on narrative portraiture and identity. The course encourages conceptual and stylistic growth. Students will exercise their skills through direct observation of facial features, contemporary portraiture and photographic images. Students are encouraged to create portraits that are expressive and explore a meaningful idea, resulting in a painted portrait on a large-scale canvas. The sketchbook will play an important role in documenting ideas, sketching, maintaining a goal-setting calendar and other process elements. Each term, students will explore the relationship between portraiture and photography, learning to take professional studio portraits in the photo studio as reference imagery for a painted or drawn portrait. Students will exhibit their final works in the end-of-term pop-up show. *Prerequisite: ART208. Offered: fall and winter terms.*

ART409: ADVANCED DIGITAL ART + DESIGN

Students will explore the digital realm of art and learn to translate their creations from the screen to the physical world. They will develop essential design skills while learning the techniques of engraving, screen printing and large-format inkjet printing. Students will learn various aspects of graphic design and illustration, including drawing on a tablet and basic software skills with programs such as Procreate, Adobe Creative Suite and Raster Image Processor (RIP) software. Building on skills and concepts acquired in the 200-level printmaking or photography classes, this advanced course provides the opportunity to pursue individual digital art studio projects using a range of media, technology, processes, inks, garments and printing surfaces. Class critiques will enhance the creation of an art collection that emphasizes advanced creative technology with AI experimentation, conceptual strength and aesthetic style. Each term, the class will collaborate as a design team to produce a limited-edition printed item and to showcase selected digital artworks for the Advanced Student Art Show. *Prerequisite: ART205 or ART206, or permission of the department. Offered: winter term.*

ART500: STUDIO THESIS

This course provides experienced students a rich opportunity to pursue the successful completion of a professional portfolio of artwork featured in an end-of-term thesis exhibition in the Mayer Art Center, team-curated by the class with a contemporary flavor. The meaningful study of 21st-century visual culture is infused in the course through visiting artists and the investigation of artists relevant to ongoing studio work. Students must build off

previous 400-level class studio experiences, media and skills. This multimedia studio course requires strong self-direction, a unique studio investment and creative motivation. Students are required to focus on a particular art medium and create artwork that explores a specific concept. Under the guidance of the instructor, students will set qualitative and quantitative goals for the term in their chosen studio concentration. Weekly process critiques are an integral part of the course and support ongoing artistic growth. Useful feedback is given to students from other Art Department faculty who specialize in their studio discipline to help them develop ideas and offer suggestions. Students may also receive guidance in developing an art portfolio suitable for college admission criteria. *Prerequisite: any 400-level studio course. Offered: fall and winter terms.*

ART690: CAPSTONE INTENSIVE STUDIO

Moving beyond ART500, Capstone Intensive Studio is a unique opportunity for in-depth studio work dedicated to concept development and supported by the required investigation of working artists and extended studio practice. This investigation will inform students' creative thinking and impact their independent studio practice. Increased individualized study provides students the opportunity to steer their work in fresh directions with serious

focus. Through the purposeful research of art historical movements and contemporary artists, students will create a strong foundation for their capstone projects in their specialized media. This effort is supported by art readings, self-assigned prompts, concept proposals, class critiques, a studio journal, increased self-reflection and written responses to contemporary art issues. Each student will produce a capstone project that will be documented and published collaboratively in a professionally printed artist book. By working collectively on this publication, students will learn how to professionally document their artwork, craft an effective artist statement, and understand their work within the greater context of the art world. This course culminates in an exhibition of capstone projects in the Lamont Gallery. The accompanying publication serves as an exhibition-in-print and visual anthology of the class capstones. *Prerequisite: ART500. Offered: spring term.*

Classical Languages

The primary goal of the Department of Classical Languages is to develop in our students the ability to read and appreciate significant works of Greek and Latin literature in the original language. The Greeks and the Romans asked fundamental questions about what it means to be human: What is goodness? What is knowledge? These are not questions that afford easy or definite answers, but people like Plato and Vergil got the ball rolling and their voices still speak to us two thousand years later. To hear these voices is to reflect on how they have been received, resisted, used and misused by many cultures that followed. More importantly, their intrinsic brilliance and originality make them worth studying for their own sake. Translations are but a pale shadow of the real thing, so by learning Greek and Latin, students gain direct access to the thoughts and feelings of the authors themselves. Many of their works are as daring now as they were millennia ago, which may surprise those who equate "classical" with "old-fashioned." Some will provoke dissent, but rather than place Greco-Roman culture on a pedestal, we want our students to engage critically with it, which in turn encourages them to question systems of value and meaning in their own culture.

To implement this goal, we have written our own introductory Latin textbook titled *Ludus* and our own introductory Greek

textbook titled *ΑΓΩΝ*. Both follow the same set of principles:

- We explicitly teach Latin and Greek grammar in a way that is student-centered and discussion-based.
- We treat Latin and Greek not as puzzles to be decoded but as languages used to express meaning.
- We ask students to read connected stories of historical and cultural interest. In addition, we believe that speaking, hearing and writing Latin and Greek will help them become better readers.

An abiding, concomitant goal is to make our students intellectually independent, both of their instructor and of auxiliary materials such as dictionaries. Our ideal is that students will acquire a truly active knowledge of Latin and Greek and so become their own best teachers and critics. Students take an active role in class from the earliest stage, whether explaining work they have displayed on the board or posing questions and suggestions to their peers. Students become able with increasing frequency to take the lead during classes, whether in assessing the accuracy of a translation or in leading the discussion of a passage of Vergil's *Aeneid* or of a Platonic dialogue.

The capstone of our program is the Classical Diploma. To fully appreciate classical literature as a product of two interconnected cultures, students should know both Latin and Greek, and the wearing of laurel wreaths on commencement day symbolizes this achievement. Students may advance even further beyond the requirements of the Classical Diploma, knowing that our department is committed to offering classes in Latin and Greek to match the highest level they are able to attain.

Although our department focuses on the study of classical languages, we also want to expose our students to other disciplines that inform the field of Classics: namely, history, archaeology and reception studies. We encourage interested students to enroll in Classical Greece (HIS203), Classical Rome (HIS204), Roman History for Latin Students (HIS314), Problems in Ancient Mediterranean History (HIS602) and/or Reimagining the Classics (ENG589).

Classical Diploma Latin Concentration

The Classical Diploma with a Latin concentration is awarded to students who successfully complete both a Latin course and a Greek course from the following options:

- › Latin 611 or Latin 530
- › Greek 431

The standard expectation is that students take 13 terms of Latin and Greek as counted by Academy courses, but a student who enters the school in grade 10 or later may, if placement precludes reaching Latin 611 or Latin 530, earn a Classical Diploma by successfully completing both a Latin course and a Greek course from the following options:

- › Latin 531
- › Greek 431

The last course in the sequence of courses in each language must be taught by an Academy teacher. Seniors who wish to earn the Classical Diploma but also to participate in the Washington Intern Program or another off-campus, spring-term program, may do so by successfully completing Latin 621 and Greek 421; students who wish to participate in off-campus programs in the fall or winter of their senior year should plan to start Greek before their senior year.

Classical Diploma Greek Concentration

The Classical Diploma with a Greek concentration is awarded to students who successfully complete both a Greek course and a Latin course from the following options:

- Greek 611
- Latin 231 or Latin 220

The standard expectation is that students take 12 terms of Greek and Latin as counted by Academy courses, but a student who enters

LATIN CONCENTRATION

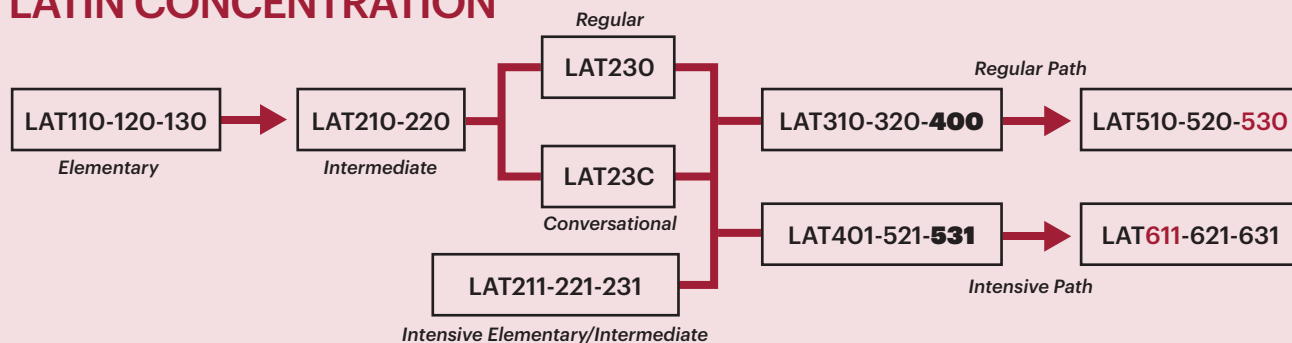

GRK411-421-431

- Graduation req.
- Classical Diploma req.

GREEK CONCENTRATION

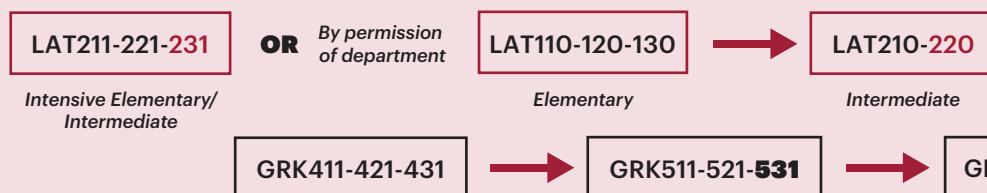

- Graduation req.
- Classical Diploma req.

the school in grade 10 or later may, if placement precludes reaching Greek 611, earn a Classical Diploma by successfully completing both a Greek course and a Latin course from the following options:

- › Greek 531
- › Latin 231 or Latin 220

The last course in the sequence of courses in each language must be taught by an Academy teacher. Seniors who wish to earn the Classical Diploma but also to participate in the Washington Intern Program or another off-campus, spring-term program, may do so by successfully completing Greek 621 and Latin 221; students who wish to participate in off-campus programs in the fall or winter of their senior year should plan to start Latin before their senior year.

Note: Comparable combinations of Latin and Greek courses may, at the discretion of the department, fulfill the requirements.

■ Greek

GRK411/421/431: ELEMENTARY GREEK — INTENSIVE

This accelerated introductory sequence is offered fall (GRK411), winter (GRK421) and spring (GRK431). It is designed for students who wish to complete the Greek requirement for the Classical Diploma (Latin concentration) in just one year. It covers the basic vocabulary, structure, and grammar of Attic Greek in two and a half terms, after which some reading is done from Herodotus, Lysias or Xenophon. No prior knowledge of Greek is assumed, but a strong foundation in Latin or another inflected language is required.

Prerequisite: LAT220 or LAT231 or by departmental permission. Meets during the reserve format.

GRK511: PLATO'S CRITO — INTENSIVE

This course begins with a review of beginning Greek that includes readings in Xenophon's *Memorabilia* and then turns to the study of Plato's *Crito*, a prose dialogue in which Socrates discusses the proper response of a citizen condemned unjustly by the laws of his own democratic state. In addition to the philosophical questions the dialogue raises for such concepts as civil disobedience, it offers students the opportunity to advance their understanding of the Greek language by reading one of the greatest prose stylists of antiquity. *Prerequisite: GRK431. Offered: fall term.*

GRK521: PLATO'S APOLOGY — INTENSIVE

Students read Plato's *Apology* in its entirety. While continuing the study of Greek prose grammar and style, this course presents students with the fundamental challenge of Plato's Socrates, a thinker who refused to expound doctrine but demanded that his listeners think for themselves and remain tirelessly dedicated to arriving as close to the truth as possible. Plato masterfully recreates for the reader this challenge to live the examined life, with all its humbling puzzles and acknowledgments of ignorance. *Prerequisite: GRK511. Offered: winter term.*

GRK531: HOMER'S ILIAD — INTENSIVE

Homer's *Iliad* is the earliest work of Western literature and perhaps its greatest. In this course, students will read Book 1 in the original Greek, attuning themselves to what Matthew Arnold gave as the dominant characteristics of Homeric style: rapidity, plainness, directness and nobility. After completing Book 1, we will read selections from other books in either Greek or English. *Prerequisite: GRK521. Offered: spring term.*

GRK611: GREEK TRAGEDY — INTENSIVE

Students will read a play written by one of the three extant Greek tragedians: Aeschylus, Sophocles and Euripides. Discussion and research may include such topics as comparison of other tragedies, ancient theatre production, the tragic literary tradition and its effect on modern theater, and how ancient Greek political life is reflected in the plays. *Prerequisite: GRK531. Offered: fall term.*

GRK621: GREEK OLD COMEDY — INTENSIVE

This course offers a close reading of one or more comedies by the Athenian playwright Aristophanes. Irreverent, incisive and, above all, entertaining, the comedies of Aristophanes laid bare the foibles and failings of Athens' democratic government and helped lay the foundations of modern political satire. Comedies read in recent years include *Lysistrata*, *Clouds* and *Frogs*. *Prerequisite: GRK611. Offered: winter term.*

GRK631: GREEK POETRY — INTENSIVE

Depending on the interests of the students and instructor, this course offers readings in either Greek epic or lyric poetry. In the epic sequence, students will read at least two books of Homer's *Odyssey* in their entirety and selections from the full 24. Students may be asked to read the full epic in English to facilitate discussion, while also leaving open the option to explore the ways this story has been interpreted over the centuries in art, literature, theater, and psychology. Lyric poetry, meaning poetry "sung to the lyre" is divided into two types: choral and monody. The former was composed mainly for public ceremonies whereas the latter, focusing on friendship, love, and hate, was probably reserved for private occasions like drinking parties. In the lyric sequence, students will read selections from both types, including works by Alcman, Simonides, Pindar, Alcaeus, Anacreon and Sappho. *Prerequisite: GRK621. Offered: spring term.*

ADVANCED SEMINARS IN GREEK — INTENSIVE

The advanced seminars in Greek immerse students in the sustained study of an author, genre or topic of their choice. In consultation with their instructor and with the approval of the department, students can select GRK711 or design their own course (GRK791). The term the course will be offered is based on availability of the instructor. *Prerequisite for all: GRK631.*

GRK711: PLATO'S REPUBLIC

A.N. Whitehead once said that all of Western philosophy was but a footnote to Plato. This course provides a close study of the *Republic*, perhaps Plato's most important and influential work. Written as a dialogue between Socrates and others, including the moral relativist Thrasymachus, it focuses on the timeless question: What is justice? Students will read the first book in the original and the entire *Republic* in translation. Special attention will be given to advanced syntax, in particular the use of Greek particles; to Plato's narrative technique; and to the line of philosophical argument developed in the text. Some additional secondary literature on ancient philosophy will be assigned.

GRK791: SPECIAL READINGS

The readings for this course vary from year to year and are dependent upon the interests of the students.

■ Latin

The following courses are those in the normal sequence that fulfill the language requirement. At times, based on the ability and training of students, the department may advance students to a higher-level course.

Students may gain admission to any course above the Latin 110/120/130 sequence by taking qualifying examinations for each respective upper-level course.

LAT110/120/130: ELEMENTARY LATIN

This sequence of courses is offered fall (LAT110), winter (LAT120) and spring (LAT130). An introduction to the study of Latin, this sequence is for beginning students and for those who have previously studied some Latin but do not place into LAT210 or LAT211. The most common forms and syntax are covered, except for the subjunctive mood. *Meets during the reserve format.*

LAT210/220/230: INTERMEDIATE LATIN

This sequence of courses is offered fall (LAT210), winter (LAT220) and spring (LAT230). LAT210 continues to introduce students to additional forms and syntax, including the subjunctive mood. After completion of this material, students in LAT220 will have their first taste of authentic Latin prose, beginning with Julius Caesar's *De Bello Gallico*. Not just a general, conqueror and dictator, Julius Caesar was also a man of letters whose writing is often heralded as the exemplar of *Latinitas*, or Latin "correctness." In LAT230, students will read the story of Cupid and Psyche from Apuleius' *Metamorphoses*, a story rich in art and myth. Students will conclude the year reading selections from Cicero's *Oration Against Verres*, the notoriously corrupt governor of Sicily. *Prerequisite: LAT130. Meets during the reserve format.*

LAT23C: INTERMEDIATE LATIN: CONVERSATIONAL APPROACH

Professor Daniel Gallagher has said, "Latin, like any language, is mastered only when one can speak it. Yet the goal of spoken Latin, unlike modern languages, is not necessarily conversational fluency. Rather, by formulating one's own thoughts into Latin and expressing them in real human-to-human interaction, one experiences the unique structural, grammatical and syntactical features of Latin actively and not just passively, and this, in turn, leads to reading fluency." This course provides students with the resources to talk about themselves and the world around them in Latin by using John C. Traupman's book *Conversational Latin for Oral Proficiency*. While developing their speaking and listening skills, students will also be reading Latin selections from Hans Ørberg's *Lingua Latina per se Illustrata* and writing in Latin about what they read without resorting to English translation. *Prerequisite: LAT220. Meets during the reserve format. Offered: spring term.*

LAT211/221/231: ELEMENTARY LATIN — INTENSIVE

This introductory sequence is offered fall (LAT211), winter (LAT221) and spring (LAT231). It serves two purposes: First, it offers students who have studied Latin previously (but are not placed into LAT210) a slightly condensed and accelerated path through the material covered in LAT110 through LAT230. Second, it satisfies the Latin part of the Classical Diploma requirement for students concentrating in Greek. *Prerequisite for incoming students: placement by the department. Meets during the reserve format.*

LAT310: CICERO

Quintilian said, "For posterity, the name of Cicero has come to be regarded as the name of eloquence itself." In this course, students will read Cicero's *First Oration Against Catiline* and discover how the consul Cicero used his rhetorical talents to denounce the disgruntled aristocrat Catiline and thwart his conspiracy to overthrow the state. *Prerequisite: LAT230, LAT23C or LAT231. Offered: fall term.*

LAT320: LATIN PROSE

Students will read selections from Pliny's Letters and other sources that shed light on the attitudes of elite Roman men toward women, enslaved persons and other non-elites in the Roman world. Through the lens of these readings and by examining relevant artifacts of material culture, they will endeavor to circumvent the biases of our sources to gain a fuller understanding of the breadth and diversity of Roman society. *Prerequisite: LAT310. Offered: winter term.*

LAT400: OVID

This course offers an introduction to poetry and meter through selections from Ovid's *Metamorphoses*, the epic poem that breathes life into our understanding of so many Greco-Roman myths. The flight of Daedalus and Icarus, the love of Pyramus and Thisbe, and the footrace of Atalanta are a sampling of the stories we will translate and discuss in depth. *Prerequisite: LAT320. Offered: spring term.*

LAT401: CICERO AND LATIN PROSE — INTENSIVE

Quintilian said, “For posterity, the name of Cicero has come to be regarded as the name of eloquence itself.” In this accelerated course, students will read Cicero’s *First Oration Against Catiline* at a faster pace than in Latin 310 and will discover how the consul Cicero used his rhetorical talents to denounce the disgruntled aristocrat Catiline and thwart his conspiracy to overthrow the state. After finishing the speech, students will then read selections of Latin prose from Pliny, Seneca, and other authors that focus on the lives of women, slaves and foreigners. Students are admitted to this course with permission of the department. *Prerequisite: LAT230, LAT23C or LAT231: with permission of the department. Meets during the reserve format. Offered: fall term.*

LAT510/520/530: VERGIL

This sequence of courses is offered fall (LAT510), winter (LAT520) and spring (LAT530). It is for those students who have taken the Latin 310/320/400 sequence and who wish to go beyond the language requirement. This sequence fulfills the Latin requirement for the Classical Diploma. The 510/520/530 sequence offers a close reading of selections from Vergil’s epic *Aeneid*, Latin poetry’s defining achievement and an enduring monument of world literature. Books 1, 2, and 4 will be read in the first, second and third terms respectively. *Prerequisite: LAT400.*

LAT521/531: VERGIL — INTENSIVE

LAT521 and LAT531 offer a close reading of selections from Vergil’s epic *Aeneid*, Latin poetry’s defining achievement and an enduring monument of world literature. This intensive sequence covers a smaller set of notable selections from the work than the regular LAT510/520/530 sequence but features more in-depth analysis of the language of the epic, its literary antecedents, and its cultural and historical context. *Prerequisite: LAT401. Offered: winter (LAT521) and spring (LAT531) terms.*

LAT611: CATULLUS — INTENSIVE

This course is dedicated to reading selections from the short *carmina* of a revolutionary young lyric poet, Gaius Valerius Catullus. Love, hate, betrayal, loyalty, invective and the art of writing itself are among the array of topics that Catullus explored in a variety of meters. *Prerequisite: LAT531, or LAT530 with permission of the department. Offered: fall term.*

LAT621: HORACE — INTENSIVE

In this course, students study many of Horace’s lyric poems (*Odes*) and at least one of his *Satires*. Horace used his verse to discuss topics essential to fundamental human happiness in the face of inevitable changes both personal and political. In addition, his poems, which combine philosophical concepts with highly crafted artistry, develop a unique voice at once congenial, sardonic and elusive. *Prerequisite: LAT611. Offered: winter term.*

LAT631: OVID — INTENSIVE

This course explores in depth the wittiest of Roman poets, Publius Ovidius Naso. First, we will read three of his *Amores*, the love poems that made him famous; then, the opening of the *Ars Amatoria*, the seduction manual that got him in trouble with the emperor Augustus; and finally, selections from the *Metamorphoses*, the epic masterpiece that has influenced more artists and writers than perhaps any other work of Western literature. *Prerequisite: LAT621. Offered: spring term.*

ADVANCED SEMINARS IN LATIN — INTENSIVE

The advanced seminars in Latin immerse students in the sustained study of an author, genre or topic of their choice. In consultation with their instructor and with the approval of the department, students can select from the courses listed below or design their own course (LAT791). The term the course will be offered is based on availability of the instructor. *Prerequisite for all: LAT631.*

LAT711: LATIN ELEGY

Quintilian famously said, “In elegy too we challenge the Greeks.” Although indebted to the Greeks, the Roman elegists created a kind of personal love poetry never seen before in literature: a cycle of poems describing a love affair with one woman or one man. We will be reading selected elegies of Propertius, Tibullus, Ovid and Sulpicia (the sole female representative), with an eye toward appreciating their poetic craft and analyzing what the genre meant to them and their audience.

LAT721: LATIN PROSE COMPOSITION

In this course, students complete an intense review of Latin grammar while also reading selections of several Latin authors with an eye toward identifying the stylistic elements that make each author unique. Students then put their Latin knowledge to the ultimate test by creating their own original compositions in the style of different authors; for example, Ciceronian oratory, Sallustian or Tacitean history, biographical works in the style of Suetonius, or letters about natural disasters inspired by Pliny.

LAT731: LUCRETIUS

Vergil said of Lucretius: “Happy is he who could understand the causes of things.” Lucretius was an ardent Epicurean who believed that the world was composed of indivisible particles called atoms and that the soul, also composed of atoms, perished with the body. In this course students will study *De Rerum Natura*, a didactic poem that Lucretius wrote to explain his philosophy and to free his readers from their fear of death.

LAT741: PLAUTUS

The comedies of Plautus are the earliest complete works of Latin literature we have. Adapting the plots of earlier Greek plays, Plautus made them his own by adding such distinctively Roman elements as the role of the clever slave, coarse Latin humor, and lots of puns and other word-play. In this course students will read Plautus’s *Menaechmi*, the model for Shakespeare’s *The Comedy of Errors*.

LAT751: ROMAN SATIRE

This course explores the meaning of the Roman interpretation of satire (*satura*, meaning “medley”) and how the literary form developed from an improvisational, personal story set to meter to a lighthearted yet dagger-sharp form of social criticism. Reading selections from Lucilius, Horace, and Juvenal, students will have an opportunity to consider how the self is perceived in and by society.

LAT761: TACITUS

Agrippina, the sister of Caligula, wife of Claudius, mother of Nero, was at the heart of the power and intrigues of the Julio-Claudian emperors for several decades. She is one of the most colorful characters in Tacitus’ history of that period with allegations of promiscuity, incest, murder and treason. Students will read extracts from Tacitus’ *Annals*, Books 12-14, taking in her marriage to Claudius, the accession of her son Nero, and her downfall. Students will become familiar with Silver Latin, and appreciate the “*brevitas, varietas, et poeticus color*” for which Tacitus is acclaimed.

LAT771: MARTIAL AND PETRONIUS

Although they wrote in different genres — Martial was a master of the epigram, while Petronius wrote something resembling a modern novel — the works of these first century CE authors are both written in language that is closer to the street than to the elevated diction of Cicero or Vergil. They are also full of amusing and incisive

observations on the daily lives of ordinary, non-elite Romans — their jealousies and desires, their occupations and preoccupations, their dining tastes and favorite entertainments, their philosophies of life and views on death.

LAT791: SPECIAL READINGS

The readings for this course vary from year to year and are dependent upon the interests of the students.

■ Classics

Note: The following courses do not give credit toward the language requirement, nor the classical diploma requirement.

HIS314: ROMAN HISTORY FOR LATIN STUDENTS

See History Department offerings for complete description. *Prerequisite of a 200-level history course and completion of LAT210 or higher (excluding LAT211). The history prerequisite does not apply to new 10th or 11th graders. Twelfth graders may not enroll. Offered: winter term.*

ENG589: REIMAGINING THE CLASSICS: HOMER’S ILIAD

See English Department offerings for complete description. *No previous knowledge of Latin or Greek is required or expected. Open to 12th graders. Offered: spring term.*

Computer Science

As embodied in the science department mission statement, “Exonians must be well prepared to enter a world of increasing social and technological complexity.” The computer science curriculum seeks to do this by focusing on algorithmic thinking, software creation and the impacts of ever-expanding technology on society.

Recognizing that collaboration is an essential part of learning in this area, Phillips Exeter Academy ensures that each computer science course involves collaborative work beyond conversations at the Harkness table. Students interested in computer science may start in one of three classes:

- CSC205: Computing and Society
- CSC208: Building the Dynamic Web
- CSC405: Algorithms and Software Creation

CSC205: COMPUTING AND SOCIETY

This course introduces students to algorithms and algorithmic

thinking through the lens of social and public policy. Students explore the impact of algorithms and software on privacy, censorship and other sometimes contentious matters in the modern world. Students will learn programming as a tool for exploring these concepts. *Co-requisite of MAT12T or higher. Not open to students who have taken CSC208 (exceptions may be made with departmental permission). Meets during the reserve format.*

CSC208: BUILDING THE DYNAMIC WEB

This course introduces students to algorithms and algorithmic thinking through the lens of dynamic website design and creation. Students will learn the skills needed for building static and dynamic web content. Tools used to create dynamic websites may include, but are not limited to, HTML, CSS, JavaScript and PHP. Students also will consider issues of site usability, design and user experience. *Co-requisite of MAT12T or higher. Not open to students who have taken CSC205 (exceptions may be made with departmental permission). Meets during the reserve format.*

CSC308: INTERACTIVE, DATA-DRIVEN COMPUTING

Building on coding concepts introduced in the 200-level courses, this course will focus on more advanced topics in creating interactive software applications. This course will explore the data structures necessary to build cohesive programs that respond to human interaction in real time. This is a project-based course where students will learn by writing software and building creative applications. *Prerequisite: CSC205 or CSC208 or with permission of the department. Offered: spring term.*

CSC405: ALGORITHMS AND SOFTWARE CREATION

This course introduces students to the fundamentals of authoring computer code using modern languages and programming paradigms. The course primarily focuses on acquiring software development skills through solving progressively more complex programming problems, culminating in a design project in which students are encouraged to leverage their creativity and interests to craft a program of their own devising. Students with prior programming experience may prefer this course to CSC205 or CSC208, though no such experience is required. *Co-requisite of MAT12T or higher. Meets during the reserve format.*

CSC505: DATA STRUCTURES AND ALGORITHMS

This course examines classic data structures: lists, queues, stacks, trees and graphs. Standard algorithms for sorting and searching will be studied, and complexity analysis performed using big-oh notation. Students will also develop a deeper understanding of software engineering principles as the course emphasizes reuse and generic programming. *Prerequisite: CSC405 or with permission of the department. Offered: winter and spring terms.*

CSC506: MOBILE APP DEVELOPMENT

In this course, students will explore mobile spaces by developing applications for one or more of the presently available platforms (Android, IOS, etc.). Students will explore development topics specific to mobile applications, device operations and user interaction. Throughout the term, sound software design and engineering practices in encapsulation and modularization will be emphasized. *Prerequisite: CSC308 or CSC405 or with permission of the department. Offered: fall term.*

CSC590: SELECTED TOPICS IN COMPUTER SCIENCE

This course will address a variety of theoretical and/or technological issues related to computer science and provides an opportunity for students to undertake a software development or research project. Topics to be covered each term are decided by the instructor in consultation with students. Students will work individually or in small groups on projects related to these topics. This course may be repeated. *Prerequisite: CSC505 or CSC506 or with permission of the department.*

COMPUTER SCIENCE FLOWCHART

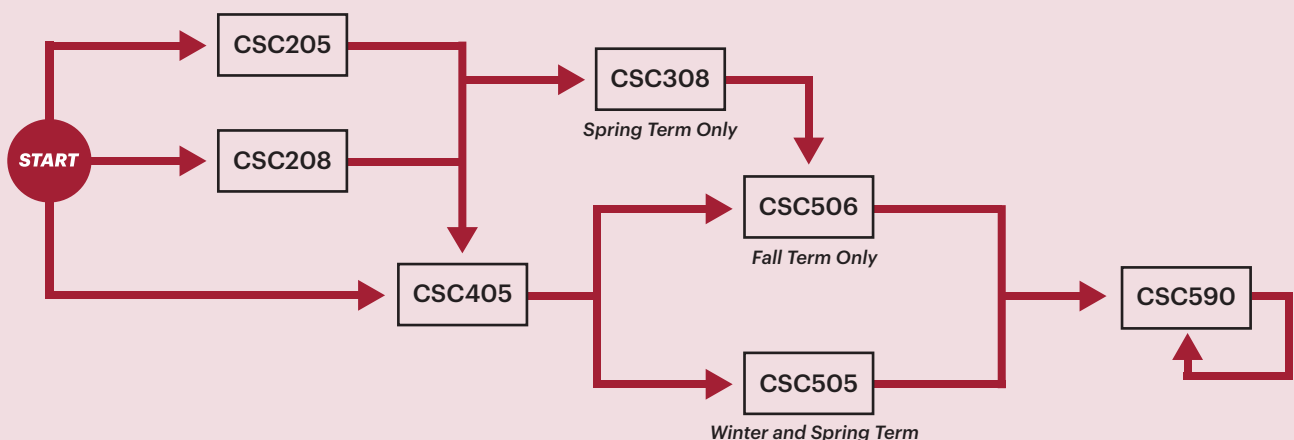

Economics

Economics helps people understand how individuals and businesses make decisions and how the interplay of market forces and government interventions in the economy affects people's well-being. Economic thinking can be instrumental in approaching societal problems such as racial and gender discrimination, environmental degradation and inequality. Students of economics also gain insight into the causes of long-run changes in standards of living across populations and of short-run fluctuations in economic performance. The discipline emphasizes an understanding of the trade-offs we face when trying to choose how to use scarce resources while preserving long-run sustainability of production and achieving an equitable distribution of the economy's output.

Students who are interested in the study of economics at Exeter may choose from five offerings.

Students interested in the history of economic development in the Western world and in the philosophies of the well-known political economists such as Adam Smith and Karl Marx, and less historically recognized thinkers such as Eric Williams, should enroll in HIS506: *Capitalism and Its Critics*, offered in the fall term.

Students who wish to understand why standards of living remain so low in dozens of countries across the world and how policies might help reduce poverty should take HIS556: *Why Are Poor Nations Poor?*, which is offered in the winter term.

Students who desire a one-term introduction to both microeconomic and macroeconomic issues should take ECO502: *Principles of Economics and Business*, which is offered in the spring term and as a summer intensive course. ECO502 emphasizes an understanding of contemporary economic and business topics, especially issues of political controversy. This course is not open to students who have already taken ECO510 or ECO520.

Finally, students who prefer an in-depth exploration of economic theory and models and of their applications to contemporary problems should enroll in one or both of the following courses: ECO510: *Macroeconomic Issues in the United States*, which focuses on the behavior of the national economy (offered in the winter term), and ECO520: *Microeconomic Theory and Policy*, which covers the behavior of individual consumers, businesses and markets (offered in the spring term). These two courses work well as a sequence, and ECO510 is a prerequisite for ECO520. However, students may choose to take ECO510 without taking ECO520; with permission of the instructor, they may be allowed to take ECO520 without having taken ECO510. In most cases, however, students who don't take ECO510 in the winter and wish to take an economics class in the spring should take ECO502 instead of ECO520.

Note: Economics courses do not give credit toward the History Department requirement. These courses may meet three class periods per week to allow emphasis on independent work.

ECO502: PRINCIPLES OF ECONOMICS AND BUSINESS

At its essence, economics studies human behavior and choice, as well as the social implications of those choices. How do we produce and distribute scarce resources? This course will examine those phenomena from both the human level and the bird's-eye view of the country and the world. We will examine the political implications of these decisions. Topics will include important micro and macroeconomic questions, such as: What is income inequality and how is it racialized and gendered? How does inequality affect the economy as a whole? What happens when we raise the minimum wage? Who are the winners and losers in international trade? When is the right time to raise or cut taxes? Where does innovation come from? What allows some to gain greater influence than others in the economy? Students will learn some theory and read numerous contemporary commentators to gain a strong introductory exposure to the serious economic questions of our time. *Open to 11th graders who have taken a 400-level history course and to 12th graders. Priority given to 12th graders. Not open to students who have taken or are taking ECO510 or ECO520. Offered: spring term.*

ECO502: PRINCIPLES OF ECONOMICS AND BUSINESS: SUMMER IN BERLIN

Designed as a three-week intensive and experiential summer course in Berlin, this course explores the same principles of economics and business taught in ECO502 on campus during the academic year, but with a focus on the German economy. *Provides one term credit. Open to rising 11th graders who have taken a 400-level history course and to rising 12th graders. Priority given to rising 12th graders. Not open to students who have taken or plan to take ECO502 on campus. To register for this course, students must apply to the Office of Global Initiatives; applications for summer programs are released in December. There is a surcharge for this course. Offered: summer.*

ECO510: MACROECONOMIC ISSUES IN THE UNITED STATES

How does a nation's economy grow, and who sees the benefits of that growth? What happens when the economy does not grow? Exploring questions such as these on the national scale is the study of macroeconomics. In this course you will examine macroeconomic theory and how it is practiced by our policymakers. You will discuss the assumptions long held, and newly re-examined, within macroeconomics. You will also examine the necessary interface of the economy with the political system, which makes this problem-solving messier than the theory might imply. Important to our understanding will be breaking down these concepts to see

how people throughout different racial, gender, generational and other segments of society experience “the economy.” Students will become very conversant in concepts such as unemployment, income inequality, fiscal and monetary policies, government budget deficits, and the role of the banking system, as well as economic crises such as those of 2008 and 2020. *Open to 11th graders who have taken a 400-level history course and to 12th graders. Priority given to 12th graders. Offered: winter term.*

ECO520: MICROECONOMIC THEORY AND POLICY

Whether the topic is electric cars, Maine lobsters or city apartment rentals, microeconomics examines in depth how markets work (or fail to work). It explores how people and businesses make decisions under different scenarios. Importantly, it also examines the impact of government intervention on market outcomes — sometimes for better, sometimes for worse. What allows some to gain greater

influence than others in these markets? And how can we harness the power of economic thinking at the ground level to influence our understanding of societal issues such as discrimination and environmental degradation? You will also consider what the limits might be of that economic thinking on social problems. We study supply and demand and the allocation of scarce resources; price controls (including the minimum wage); taxation and its effects on consumers and producers; income distribution; and environmental regulation. We also discuss business decision-making (in competitive markets, monopoly and oligopoly), financial markets, and international trade and protectionism. *Prerequisite: ECO510 or permission of the instructor. Open to 11th graders who have taken a 400-level history course and to 12th graders. Priority given to 12th graders. Offered: spring term.*

English

The teaching of English at Exeter is shaped by the conviction that language is the essential means of gaining self-knowledge and of participating in community. The emphasis may vary from course to course, but the goals of instruction are constant: the development of skills of expression and of listening and understanding. The courses in our required sequence (ENG100 through ENG500) are differentiated primarily by the increasing complexity and sophistication in the writing we expect and in the works we read. In their senior winter and spring, students choose from a range of electives focusing on particular writers, topics or genres. At every level, students are likely to write in various forms and to read works representing diverse voices and experiences.

Each year, the Academy sponsors a writer-in-residence, the George Bennett Fellow. In addition, poets and prose writers regularly visit campus to read from their own work and to meet with groups of students. Two student publications, *Pendulum* and *Peal*, feature student prose and poetry.

9th Grade

ENG100/210/220: 9TH-GRADE ENGLISH

In this sequence of courses, the English Department introduces 9th graders to the reading practices, discussion principles and writing strategies they will use and on which they will build throughout their four years of English study at Exeter. Ninth graders read, discuss and write about poems, short stories, novels and plays designed to introduce them to the art of writing about their

own lives. Students write personal narratives throughout their four years at Exeter but focus heavily on this genre during their first two years. Assignments, feedback and frequent writing workshops help students create convincing characters and a sense of place in their narratives, and hone their skills as readers and editors of one another’s work. Special emphasis is also placed on participation in class discussions; students take time to reflect on and refine their individual discussion skills and identify ways in which they and their peers might work together more productively. Initially, students write short descriptive and narrative pieces before beginning to produce longer, more sustained personal narratives as the year progresses. They also explore their readings through analytical writing, whether in journals, short in-class writing assignments or online discussion boards. In all these ways, the English 100/210/220 sequence prepares 9th graders for the increasingly demanding work they will do — as readers, as discussion partners, as writers — in future English courses.

Lower Year

ENG310/320/330: 10TH-GRADE ENGLISH

In this sequence of courses, readings introduce broader, more complex personal and social topics. The writing program emphasizes personal narratives but may include editorials, poetry projects, dramatic writing and responses to the readings. Assignments foster awareness of audience and exploration of perspective. During the winter term, writing assignments encourage exploration of racial identity, and readings and discussions help students develop a critical understanding of race in literature in order to prepare

them for further discussions of identities as they move through the curriculum. In the spring term, students write a sustained narrative piece, often based on research into their family history.

Upper Year

ENG410/420/430: 11TH-GRADE ENGLISH

In this sequence of courses, writing assignments shift from personal narratives to personal and analytical essays in which the exploration and articulation of ideas increasingly influence content and structure. Readings continue to grow in complexity of subject matter and style. In the spring term, students complete a longer, more ambitious essay.

Senior Year

■ Senior English Fall Term

ENG500

In the final sequential course in the English curriculum, writing assignments continue to focus on various forms of essay writing, culminating in a sustained exploration of a topic or theme — the Senior Meditation or an equivalent capstone assignment. Readings continue to grow in complexity of subject matter and style.

■ Senior English Winter and Spring Terms

The English Department offers a variety of elective courses to seniors during the winter and spring terms. Course offerings focus on creative writing, individual authors or literary topics. Seniors choose English courses during the registration period in the spring prior to their senior year, at which time they may enroll in one elective in each term. Seniors may enroll in additional elective courses upon the announcement at the end of the registration period.

ENG502: CREATIVE WRITING: SHORT FICTION

This writing-intensive course invites students to explore fiction as both readers and writers. The short stories and novels read in class will serve as models for students to create their own fictional work, introducing them to the craft and mechanics of fiction and storytelling. This course traditionally offers an MFA-style workshop model, providing students an opportunity to both receive and offer constructive feedback, and to revise their work using this input. Assignments may include two or three short stories and an analytical essay over the course of the term. *Offered: winter term.*

ENG503: CREATIVE WRITING: POETRY

“Poetry,” wrote Robert Frost, “is a way of taking life by the throat.” From its origins in oral tradition and tribal lore, as well as its role in incantatory spiritual practice, poetry has carried in its rhythms the deep longings of humanity. In this course, students will dip into this current, writing poems with a view to aspects of craft modeled

by poets in a diverse range of voices and writing traditions. In our workshops of one another’s poems, we will consider the relationship between content and form, as well as what differentiates poetry from other writing genres. Through experiments in received forms (traditional forms such as the sonnet and sestina), as well as more contemporary approaches (for example, writing in free verse or in prose poems), students will move toward the development of a distinctive voice and style. *Offered: winter term.*

ENG505: CREATIVE WRITING: CREATIVE NONFICTION

“The essay isn’t a retreat from the world but a way of encountering it,” writes Leslie Jamison in *Best American Essays 2017*. Throughout the term, we will explore the art of telling stories — ours and those of others — and learn how to translate personal experience and research into effective pieces of creative nonfiction. We will read and listen to essays on a range of topics: health care, bird watching, immigration, craft beer, hunting and Serena Williams (to name a few). Forms will vary from traditional to more contemporary and innovative — memoir, lyric essay, braided essay, graphic essay, podcast and video essay. We will discuss them as readers (digesting content) and as writers (analyzing form). Students will craft original pieces of creative nonfiction, experimenting with a variety of compositional elements and techniques. The writing process will be workshop-oriented: Students will receive peer and instructor feedback, work through multiple drafts and build a supportive writing community. *Offered: spring term.*

ENG508: INTRODUCTION TO AFRICAN AMERICAN LITERATURE

This course is an introduction to African American literature. Because most enslaved people were forbidden to read and write, literacy became a powerful tool in early movements for self-determination. We will read poems, short stories, essays and drama that explore the evolution of Black literary identity. Possible authors include Octavia Butler, Ta-Nehisi Coates, Paul Laurence Dunbar and James Weldon Johnson. Students will write response papers, give an oral presentation and compile a final anthology project. *Offered: winter term.*

ENG509: INTRODUCTION TO CONTEMPORARY U.S. LATINX LITERATURE

This course will explore the nuances of U.S. Latinx literature and culture by examining the specificity and diversity of Latinx experience in short fiction, poetry, personal essays and/or novels by authors such as Sandra Cisneros, Manuel Muñoz, Helena Viramontes, Junot Díaz and Judith Ortiz Cofer. Its primary aim is to provide students with a historical and literary foundation for further exploration of Latinx literature in the 20th and 21st centuries. The class will focus on the contrasts and similarities that have developed the cultural landscape among varying Latinx communities. Course objectives will include discussing and analyzing major authors, themes, narrative strategies, and literary and artistic tropes that are current in contemporary U.S. Latinx literature. Writing assignments will be a combination of innovative approaches to literary analysis and a creative writing portfolio. *Offered: spring term.*

ENG512: PLAYWRITING

Playwriting is a course designed to offer a unique and immersive experience that fuses creativity, literature and performance, providing students with the opportunity to create and develop new works. Students will look at the origins of storytelling from the time of Aristotle and Sophocles, examining how their belief in the gods influenced their writing. Then the class moves to Nietzsche, who declared “God is dead,” and considers how the death of the divine influences contemporary playwrights. Course objectives include developing techniques in playwriting, including plot development, character creation, dialogue and dramatic structure, and analyzing and critiquing works of theater, both classic and contemporary, to inform and inspire the creative process. Looking at *Oedipus Rex*, *Hamilton* and *Oh, Mary!* among other plays, as well as readings on the art of acting, students will write a monologue, expand to a three-page play and culminate the term with a 10-page play. Assessment will be based on participation, individual playwriting assignments, and peer review and self-reflection. *Students may choose to take the course for either an English credit or a theater credit (providing one term of credit toward the studio/performance arts requirement); they should consult with their adviser and college counselor before submitting this request to the Scheduler. Offered: winter term.*

ENG532: THE JEWISH LITERARY IMAGINATION

Primo Levi’s short story “Quaestio de Centauris” describes a centaur living in exile from others like him in the human world. In her discussion of this story for a series in *The New Yorker*, Jhumpa Lahiri describes Levi’s time in Auschwitz as “the most brutal form of exile” and later quotes Levi on the subject from *The Truce* when he writes: “This is the most immediate fruit of exile, of uprooting: the prevalence of the unreal over the real.”

The imaginative worlds of writers are necessarily influenced by their lived personal and inherited cultural experiences. In this class, we will consider the ways in which history, exile and intergenerational inheritance shape the artistic worlds Jewish writers create. While the readings in this course will focus on a particular literary tradition, the course is relevant and welcoming to students of all cultural backgrounds. Writing assignments will ask students to reflect on their own lives and heritage, and the ways that history, culture and diaspora hold meaning for them as community members, individuals, thinkers and artists. Assignments will range from the personal (poem, essay, short story, visual work) to the collaborative (interview, documentary, ekphrasis, collage), inviting students to consider the forces that influence their own imaginations. Readings will include fiction by Clarice Lispector, Primo Levi, Grace Paley, Franz Kafka and Courtney Sender; poetry by Anthony Hecht, Adrienne Rich and Joseph Brodsky; and criticism by Walter Benjamin, Svetlana Boym and others. The course will include visiting lecturers from within and outside of the Phillips Exeter community. *Offered: winter term.*

ENG533: GOTHIC LITERATURE AND HORROR

Haunted houses. Vampires. Ghosts. Monsters and the monstrous. Things that scare us and make us question reality are the most

notable aspects of Gothic literature and horror. This course will trace the development of Gothic literature from its earliest beginnings to its present-day forms to emphasize its influence on horror in literature and film. Students will read, explore and discuss literature defining or containing elements of the Gothic and horror while considering how the genres serve as vehicles to explore greater societal issues (particularly misogyny, racism, marginalization and othering) as well as our fears of the unknown. Students will begin their exploration with the first known Gothic masterpiece, Horace Walpole’s *The Castle of Otranto*, before continuing their exploration into the uncanny, monstrous and horrific with writers such as Edgar Allan Poe, Shirley Jackson, Victor LaValle and others. As students develop an understanding and appreciation of the complexities of these darker forms of literature, they will write critical reactions to course texts and present a final project of their own design. *Offered: spring term.*

ENG534: WHAT ARTIFICE; WHOSE INTELLIGENCE? AI THROUGH A LITERARY LENS

AI seems to be everywhere these days, whether in the news, conversations or our collective imagination. We worry that AI will replace jobs and render creativity obsolete, even while holding out hope that it might help uncover cures for diseases and replace drudgery with more meaningful pursuits. What role can literature play in our understanding of AI? If we rely on literature to “hold a mirror” up to our present, maybe it can yield new insights into what it means to be human and what kind of world we want to live in. We’ll begin with a brief history of AI, then read the work of writers like Borges and those in the OuLiPo movement who anticipated many aspects of large language models. Then we’ll jump to contemporary fiction, poetry and creative nonfiction, much of it published in the past couple of years, in which AI plays a central role, sometimes as a character, sometimes driving the plot, and sometimes as a means for the author to critique the culture that designed it. In addition, we’ll listen to podcasts such as “The AI Breakdown” and read essays such as Ted Chiang’s “Will AI Become the New McKinsey?” to enter into current cultural conversations about the practical, social and ethical implications of AI. Students will do weekly responses to readings and assemble a final portfolio of creative/analytical work that responds to the issues that arise through their reading and listening. No technical knowledge is necessary — just curiosity and a willingness to grapple with challenging questions. *Offered: spring term.*

ENG535: THEATER OF WAR: STAGING RACE, RELIGION AND EMPIRE

Representation matters. Representation on the page and on the stage — paired with power — has material consequences. This course examines representations of race and religion in the context of war and empire in classical, early modern and contemporary theater. Students will closely read texts like *The Trojan Women* by Euripides, *The Tragedy of Othello* by Shakespeare, *Father Comes Home From the Wars* by Suzan-Lori Parks, *X: Or, Betty Shabazz v. The Nation* by Marcus Gardley, *Disgraced* by Ayad Akhtar and *The Palgrave Handbook of Theatre and Race*. By reading a range of plays

contextualized in wars from different time periods, students will put on their dramaturgical goggles and consider how the contexts of the texts' original audiences inform the writing and staging of the work. Writing assignments will include analytical and creative papers and a collaborative project. *Offered: winter term.*

ENG536: POSTCOLONIAL LITERATURE AND THEORY OF AFRICA, ASIA AND THE AMERICAS

This course is an introduction to postcolonial literature and theory. Contemporary postcolonial literature refers to literature created in the formerly colonized nations (or currently colonized nations — depending on whether you believe postcolonial nations ever really achieved independence after European colonization) of the 20th and 21st centuries. In this course, we will explore different genres of postcolonial works, including novels, essays, poetry and plays, that grapple with European colonialism by writers from Africa, Asia, Central and South America, and the Caribbean during and after the independence movements of the 20th century. Assigned readings may include *Paradise* by Abdulrazak Gurnah, *A Tempest* by Aimé Césaire and *The God of Small Things* by Arundhati Roy. We will also read excerpts of *Orientalism* by Edward Said, the foundational work of postcolonial theory, and *The Wretched of the Earth* by Frantz Fanon. Possible writing assignments will include discussion posts, analytical papers and a collaborative writing project. *Offered: spring term.*

ENG537: SHAKESPEARE NOW

Poet Ben Jonson said of Shakespeare that he “was not of his age, but for all time.” But what does a poet-playwright, dead now some 400 years, have to say that speaks to this moment of the human experience? In this class we will read and discuss the Bard’s plays in order to see how they were understood in their time as well as how they address modern sensibilities of race, gender, sexuality, economics and politics. How does *Measure for Measure* figure in the #MeToo movement? What does a queer reading of *Twelfth Night* yield? How does *The Tempest* engage colonialism, race and the violence of language, or how does *King Lear* take on the betrayal of both the body and the body politic? How might *Henry IV* address cultural appropriation and entitlement or *Henry V* espouse or critique nationalism? Through discussing, writing about and even performing scenes from some of Shakespeare’s plays, we will test whether and how these works still resonate. *Offered: winter term.*

ENG542: JANE AUSTEN

In this course, we will study Austen’s novels with a focus on her use of language to show the universal tension between raw desire — for money, power and love — and the restrictions placed on that desire by social conventions and internal conflict. Despite her quiet life in the English countryside of the early 19th century, Jane Austen captured this tension in a way that echoes through the ages, such that her works continue to be adapted for stage and film today (and even borrowed for new written works, such as *Pride and Prejudice and Zombies*). As we study Jane Austen’s intricately calculated plots and consider how action releases meaning, we will also think about how people get it wrong or get it right with language, examining in

particular the role of intellect and humor in both concealing and revealing the truth as we manage our emotional lives. Students will write short pieces analyzing and perhaps imitating Austen’s style. *Offered: winter term.*

ENG543: JAMES BALDWIN

If ever there was a time to celebrate Baldwin, it is now. “Only an artist can tell what it is like for anyone who gets to this planet to survive it,” he said. This course will explore Baldwin’s early life in Harlem, New York City, in the 1920s to 1940s, his emergence as a writer and citizen of his mind, his relationship with America and his emigration to France. Through the study of his *Collected Essays & Collected Fiction*; Peck’s film *I Am Not Your Negro*; Baldwin’s conversations with a range of thinkers from Malcolm X to William F. Buckley; and the complexity of personal questions he raises in himself and in us, we will honor Baldwin’s legacy as a civil rights intellectual and activist concerning the intricacies of racial, sexual and class distinctions in Western societies. Student writing will embrace Baldwin’s spirit in the creative-intellectual process: “When you’re writing, you’re trying to find out something which you don’t know.” *Offered: spring term.*

ENG544: SAMUEL BECKETT

Nobel Prize-winning Irish author Samuel Beckett once said, “Every word is like an unnecessary stain on silence and nothingness.” And yet *his* words have proven central — necessary even — to the way many have come to experience and understand life in a world seemingly void of transcendent meaning and value. Beginning with his best-known work for the stage, *Waiting for Godot*, we will explore Beckett’s short plays and prose. Along the way, students will write creative and analytical pieces, and at term’s end they will stage a festival of “Beckett Shorts,” works chosen from the plays we have read during the term. *Offered: winter term.*

ENG548: ZORA NEALE HURSTON

In this course, we will examine the life and work of Zora Neale Hurston, “A Genius of the South.” While she is best known for the novel *Their Eyes Were Watching God*, she published more than 50 short stories, essays and plays. She was also an anthropologist, journalist and filmmaker who traveled throughout the American South and the Caribbean collecting black vernacular culture. Some questions we might take up include: What is the relationship between literature and anthropology in Hurston’s work? How does her work converge with and depart from that of her contemporaries? What is the ongoing legacy of her writing? Writing assignments include short analysis papers, folklore collection and an in-class presentation. *Offered: spring term.*

ENG552: NOVELS OF KAZUO ISHIGURO

Topically, the fiction of Japanese-born British Nobel Laureate Kazuo Ishiguro is elusive, whether he is evoking the complexity and trauma of post-war Japan, improvising with Arthurian legend or flirting with dystopian science fiction. He’s a shape-shifter, but the thematic DNA behind his often heartbreaking narratives and beguiling

narrators is unmistakable: memory and the circuitous routes through trauma, regret ... and redemption. Written work might include short analytical annotations and creative imitations. In rotation, recently: *A Pale View of Hills*, *An Artist of the Floating World*, *The Remains of the Day* and *Never Let Me Go*. Offered: winter term.

ENG555: OUTLAWS AND OUTCASTS: THE NOVELS OF CORMAC MCCARTHY

Cormac McCarthy once wrote, “If it doesn’t concern life and death, it’s not interesting.” Not surprisingly, his novels abandon the domestic in favor of the epic. They explore the inevitability of conflict, the nature of evil and our propensity for violence. His characters meet civilization at its margins — in the backwoods of Appalachia or the desolate spaces of the Southwest. McCarthy takes on American myths of rural tranquility or the West as a land of hope and opportunity, examining instead the warping effects of poverty and isolation, and the barbarity of westward expansion. *Blood Meridian*’s demonic villain, the Judge, declares that war is the “ultimate trade” and man its “ultimate practitioner.” McCarthy’s stories leave us to consider whether the Judge was right, or if redemption is possible in spite of our nature and history. Readings may include *Blood Meridian*, *No Country for Old Men* and *The Orchard Keeper*, among others. Writing assignments will include analytical and creative papers. Offered: winter term.

ENG556: MOBY DICK

Journey with Ishmael as he sails on a Nantucket whaling ship under the command of the despotic Captain Ahab on his mad hunt for the great white whale. Subversive, queer, philosophical, political and groundbreakingly experimental, Herman Melville’s great masterpiece is an epic prose poem that not only strikes through the mask of America’s democratic idealism, piety, exceptionalism and capitalistic zeal but also sets its gaze on a still young nation’s original sins of racism and environmental destruction. It is the story of rugged individualism, of brotherhood, of faith and of existing in the doubts. It is also just the story about all of us trying to hunt down our monsters as we stare into the abyss to see what stares back. Students will keep a whaling journal, write regular critical reactions to readings and present a final project on a topic from the book. Offered: spring term.

ENG558: TONI MORRISON

Throughout her decorated career, Toni Morrison celebrated the African American experience as a central and essential component of American history. At the time of her passing in 2019, she was recognized as one of the most important writers of the 20th century. When she published her first novel, *The Bluest Eye*, in 1970, she had already distinguished herself as a force to be reckoned with as an editor at Random House. Over the next half-century, Morrison published over a dozen novels (including *Song of Solomon* and *Beloved*), several influential collections of nonfiction, and award-winning children’s books. She was also awarded the Nobel Prize in literature. This course offers students the opportunity to explore the ways in which Morrison’s fiction and nonfiction reimagine American

history through the lens of the African American experience. Throughout the term, students will write short pieces analyzing and perhaps imitating Morrison’s celebrated and unique style. Offered: winter term.

ENG560: SALMAN RUSHDIE: NAMING THE UNNAMABLE

Rushdie, the multiple-award-winning author of *Midnight’s Children*, *The Satanic Verses* and *Haroun and the Sea of Stories*, was twice named the “winner of all winners” on the 25th and 40th anniversaries of the Booker Prize. His novels are gargantuan in scope and history, though not always in length, and his combination of magical realism and historical fiction has won him both avid fans and furious critics. *Midnight’s Children* follows the life of a group of children born on the night of India’s independence, all of whom possess varying degrees of special powers. *The Satanic Verses*, his most controversial work, was perceived by some as anti-religious and drew a fatwa from Iran’s Ayatollah Khomeini in 1989. The ensuing diplomatic tension between the U.K. and Iran indicates both Rushdie’s profile and the magnitude of the response to the threats to his free speech. He sets his work in India and Pakistan and explores the experiences of migrants, political figures, religious authorities and ordinary folk. Writing assignments will include analytical and creative essays. Offered: spring term.

ENG566: GRAPHIC NARRATIVE AND LITERARY COMICS

In this course, we will explore the literary phenomenon of the graphic novel and other graphic genres that blend visual storytelling and the written word. What happens to narrative when it unfolds in a hybrid form that joins image to text? What can this verbal-visual genre do that other literary genres can’t? How do we read a text in which two narrative tracks (one verbal, the other visual) interact? In addition to considering these questions through a range of graphic novels, essays and histories, students will practice their visual storytelling skills through crafting a graphic narrative of their own. Other assignments might include short analytical pieces, visual and written responses to our texts, and personal stories or essays that might resonate both textually and visually. Readings will be drawn from works by Rebecca Hall (*Wake*), Lynda Barry (*What It Is*), Scott McCloud (*Understanding Comics*) and Daniel Clowes (*Ghost World*), as well as graphic adaptations of “classics” such as Manga Shakespeare (*Hamlet*, *Macbeth*), Octavia Butler (*Parable of the Sower*) and others. Offered: spring term.

ENG567: FICTIONS OF FINANCE

What do we value? The pursuit of profit, surges in wealth and the suspect principles of the financier have intrigued authors since the 19th century. How do language, narrative style, structure and literary production transform with shifts in the marketplace? Through a careful investigation of literature, film and illustration, we will discuss how art imagines and redefines social and economic relations. We will supplement the literary works with historical documents or articles that shed light on the economic climate at the time of publication. We might consider how the imagined space of the novel presents the mystery of the financial market, which seems

shrouded in a haze. We might also ponder how authors imagine worlds where money has no practical use and nothing has any purchasing power. Over the course of the term, students will write short analytical pieces and complete a creative independent project of their own design. *Offered: winter term.*

ENG570: PAGES TO SCREEN: FILM ADAPTATIONS

Students read novels, short stories, essays and plays and study their transformation into films. Through these comparisons and a short study of key film techniques and perspectives such as auteur theory, students learn how to “read” a film. The class studies works such as *A Clockwork Orange*, *Apocalypse Now*, *Atonement* and Alice Munro’s *Runaway*, among hundreds of possibilities. Paper topics emerge from the material read and viewed. *Offered: winter term.*

ENG572: LITERATURE AND THE LAND

In this course, students will participate in outdoor excursions that prompt them to contemplate their relationship to the natural world. Drawing on an array of classical and contemporary environmental writers, including Edward Abbey, Gretchen Legler, Henry David Thoreau, Rebecca Solnit, Annie Dillard and Aldo Leopold, we will examine models of terrain becoming text. Our discussions will be far-reaching, and students will emerge with a clearer sense of environmental literature’s aesthetic and ideological contours. Written work will afford students the chance to practice the close observation and precise attention to detail required in writing effectively about the natural world. In order to foster a deeper connection to local landscape and to better understand human interaction with it, a portion of our field time may be dedicated to a local environmental service project chosen by the class. *This course meets during a reserve format in order to create a double-format meeting time for fieldwork. Offered: spring term.*

ENG573: BEATS, RHYMES AND NARRATIVE

Hip-hop music’s influence on popular culture, literature, entertainment and politics is undeniable. This course will examine the relationship between hip-hop and storytelling. Course texts will consist of weekly listening sessions, scholarly articles on hip-hop theory and definitive text on hip-hop culture. We will listen to selected songs by a diverse array of artists and analyze their structures and traditional literary elements. A section of the course will be devoted to the study of a chosen album. Class discussions will examine hip-hop as a modern-day social justice tool and a narrative genre that explores gender, race, spirituality, class and resistance. Writing assignments will consist of original rap songs, which include recordings, and a final epistolary project. *Offered: spring term.*

ENG576: ART OF PROTEST

This course examines protest as a form of literary activism. From the grittiness of hip-hop lyrics to the density of civil disobedience tracts, this class will seek to explore distinct genres of vocalizing dissent. The approach is multicultural and interdisciplinary, and it seeks to inspect the role of literature, art, music and film in

galvanizing communities and creating spaces to examine social justice. Students will be asked to write in various protest genres (poetry, epistolary witness, monologue and fiction) to compile a portfolio of their own literary activism. *Offered: winter term.*

ENG577: BETWEENITY: BELONGING BEYOND BINARIES

This course will explore literary genres and films by LGBTQIA+ creatives/scholars. We will contemplate together acts of interpretation and imagination in what contemporary thinkers call “betweenity:” non-binary, gender-queer lenses/ways of knowing. Through the celebration of historically marginalized voices and queer literary practice, we will consider the writers’ lives, the role of queerness in literature and ways to perform a queer reading. Gender performance, queer epistemology, querying the body, genre-bending, intersectionality, disability poetics, and linguistic codes embedded and chosen in artistic expressions will guide us. We will listen across and beyond borders to transnational, transcultural, multiethnic voices and study the interplay of contexts that have affected and influenced creatives and still do. Collections may include *Freedom in this Village*, *Queer Nature* and *Queer Cinema in the World*. Voices may include Sappho, June Jordan, Adrienne Rich, Audre Lorde, Judith Butler, James Baldwin, Ocean Vuong, Paul Tran, Denise Uyehara, Camila Sosa Villada, Roxane Gay, Zaina Arafat, George Abraham, Alice Wong, Callum Angus, Orit Fouks Rotem, Anurupa Prakash, Rob Epstein and Taylor Mack. Students will be invited to imagine and experiment with works of writing and art inspired by their lived experiences and their study in this course. *Offered: winter term.*

ENG578: CHILDREN’S LITERATURE

How did you come to be the reader you are? What ideas about the world and its characters did you gain from the stories you read as a child? Why did you read and reread some books? How did illustrations work with words to create the stories you saw and read? What larger issues of psychological development and culture can be understood in the stories adults create for children? Students will explore these and other questions by reading and discussing various genres and levels of children’s literature, including fairy tales, picture books, poetry and novels. Written assignments will include a reader’s journal, a short research paper, a children’s story and a final project. *Offered: spring term.*

ENG579: SPRING IN LOVE

Literary lovers, it seems, break the rules, exploring the boundaries set by family, society, religion or law. What can we learn from their defiance? Why does such love so often end in disaster? Is love socially constructed or universal? We will explore these and other questions through a variety of genres. Possible readings include cross-cultural myths and legends, something Shakespearean, Hwang’s *M. Butterfly*, Austen’s *Pride and Prejudice*, Woolf’s letters, and the films *My Brilliant Career*, *Cyrano de Bergerac* and *Tess of the d’Urbervilles*. Students will keep a journal of reader responses and design a final project. *Offered: spring term.*

ENG581: POETRY AND SONG

An exploration into the deep and longstanding relationship of poetry and song, this course asks (among other things) how the presence of music alters and enhances our experience of poetry; what qualities make song lyrics “poetic”; and how songwriters use the marriage of words and music to achieve particular effects. Students will try their hands at composing songs and at term’s end will hand in a portfolio showcasing their analytical and creative compositions. *The ability to play a musical instrument or read music is not required for this course.*

Offered: winter term.

ENG582: SCIENCE FICTION AND FANTASY

Whether it is Tolkien’s *Lord of the Rings* or H. G. Wells’ *The War of the Worlds*, science fiction and fantasy can not only delight our imagination but also help us understand our real, present world more thoroughly. Students in this course will study a wide array of science fiction and fantasy. They’ll look at how fantasy provides commentary on race, gender and class through works such as Octavia Butler’s *Fledgling* or Ursula K. Le Guin’s *The Left Hand of Darkness*, and consider science fiction’s power to comment on technological and social quandaries, such as Frank Herbert’s prescient consideration of global warming in *Dune* or Philip K. Dick’s exploration of artificial intelligence and identity in *Do Androids Dream of Electric Sheep?* Students will write critical reflections, examining the intersection of these imagined worlds with real life as well as trying to craft science fiction or fantasy of their own. *Offered: winter term.*

ENG583: STRANGER IN A STRANGE LAND

Drawing from a range of essays and literature about travel, this course seeks to equip students with the tools to process and reflect upon their own personal journeys, abroad and otherwise. Through a range of assignments, we will examine closely what it means to embark upon a journey: Why do we travel? What is the difference between a traveler and a tourist? How do we shape, and how are we shaped by, a new environment? And how far does one have to go, exactly, to undergo that ever-elusive transformation? This class will provide students opportunities not only to write and reflect upon their own travels through journal-based narratives, reflective essays, analytical papers and creative presentations, but also to tackle the deeper questions of what it means to be a global citizen, and how we learn to become at home in the world (or not). No passport required! *Offered: winter term.*

ENG584: BASEBALL: THE AMERICAN NARRATIVE

A. Bartlett Giamatti, former president of Yale and commissioner of Major League Baseball, believed that this game is “the plot of the story of our national life.” In this course we will look at how baseball reflects, embodies and illuminates modern America’s history, culture, politics, myth and racial divisions. We will also examine the game itself as a narrative — one that unfolds and reveals and surprises; one that demands close reading to understand its nuances, symbols and structure. And we will look at how various artists have used baseball as a central metaphor in their fiction,

nonfiction, poetry and film. Texts will be chosen from the works of Dubus, Malamud, Updike, Kinsella, Hall, Giamatti, Kearns-Goodwin, Moore and Exley. Possible films: Ken Burns’ *Baseball* series, *Eight Men Out*, *Field of Dreams* and *Bull Durham*. Students will write a number of short papers and complete a final project. *Offered: spring term.*

ENG585: VISIONS OF PARADISE? UTOPIAS AND DYSTOPIAS IN LITERATURE

Fantastic societies have held a fascination for writers from Thomas More to the present day. Utopia, “no place,” represents an idealized society whose inhabitants willingly embrace its difference from our own world. Dystopic visions are the disturbing flip side of this coin. Both genres inevitably cause readers to draw parallels between their own experiences and those of the protagonists. Scientific and technological advances are often at the root of the utopic/dystopic discourse, and one of the main functions of this course is to explore the presentation of technology as narrative. The course seeks to examine some of these alternate worlds to explore the way writers of fiction and filmmakers have presented the effect of projected changes and developments on the fabric of society. We will build our visionary galaxy from the following: Thomas More, Aldous Huxley, George Orwell, Margaret Atwood, Cormac McCarthy, Alfonso Cuarón, and other contemporary writers and filmmakers. Students will write analytical and creative essays. *Offered: spring term.*

ENG586: WRITING THE BODY

“I’ve only ever wanted to write about what it feels like to be alive, and it turns out being alive is always about being in a body. We’re never *not* in bodies: That’s just our fate and our assignment.” (Leslie Jamison, “Why Writing About Bodies Is Vital.”) What are the stories we tell ourselves about our bodies? In this course, we’ll study how representations of the body in art, diary, poetry, nonfiction and more inform our thoughts about the body and whether or not we are who we are despite our bodies or because of our bodies. Students may also be asked to curate select classes by choosing poems, essays or excerpts from texts already on our reading list to discuss through the lens of the body. Writing assignments will range from the descriptive (the body in form) to the contemplative (the body in culture). *Offered: spring term.*

ENG588: CRIME FICTION

This course introduces students to early works in the development of the “detective story” (Edgar Allan Poe, Agatha Christie, Sir Arthur Conan Doyle) and the ways in which those early works help establish the foundations for a variety of “crime fictions” that have steadily grown in popularity throughout the 20th and 21st centuries. Students will learn to appreciate authors working in different times, places and settings and to explore the criminal mind and those tasked with solving criminal cases and fighting criminal activity (whether amateur detective, private eye or police officer). Along the way, students will try their hand at writing their own pieces of crime fiction and produce short analytical pieces examining the books and films they encounter. *Offered: winter term.*

ENG589: REIMAGINING THE CLASSICS: HOMER'S *ILIAD*

The literature of ancient Greece and Rome has been received, resisted, used and abused by every culture that followed. Homer, who died more than 2,000 years ago, has had a rich afterlife, becoming the model for Vergil and then influencing Dante Alighieri, John Milton, Derek Walcott and Margaret Atwood. Homer's ghost still speaks to us today, and we speak back to it, and this dialogue with the past says as much about Homer as it does about our own values and preoccupations. In this interdisciplinary class, taught jointly by a member of the Classical Languages Department and a member of the English Department, we will select a single work of ancient Greek or Roman literature, read it in translation and then trace its afterlife from antiquity to the present day. The case study for spring 2026 is Homer's *Iliad*, the oldest work of Western literature. It is, above all, the epic of war — a constant of the human condition. The 20th century was notable for the scale and brutality of its world wars, and thus far the 21st century has been marked by regional conflicts of similarly tragic severity. So, we will start by reading Emily Wilson's English translation of the *Iliad* and then jump to modern retellings and re-imaginings in such genres as poetry (*War Music* by Christopher Logue), drama (*An Iliad* by Lisa Peterson and Denis O'Hare), nonfiction (*Achilles in Vietnam* by Jonathan Shay), philosophy (*The Iliad, or The Poem of Force* by Simone Weil), science fiction (*Ilium* by Dan Simmons), young adult fiction (*The Song of Achilles* by Madeline Miller) and cinema (*Troy* directed by Wolfgang Petersen). The course will culminate in a final creative project that will allow students to speak back to Homer in their own voices. *No previous knowledge of Latin or Greek is required or is expected. Offered: spring term.*

ENG602: ADVANCED CREATIVE WRITING/PORTFOLIO INTENSIVE

This course provides advanced student writers a rich opportunity to pursue the successful completion of a polished portfolio of creative writing in a variety of genres — poetry, short fiction, creative nonfiction and playwriting. As an advanced writing intensive, it requires strong self-discipline, a demonstrated investment in creative writing and an openness to experiment. The course combines student discussions of craft and primary materials with talks by visiting writers and PEA faculty who are at work in the specific genres. During the first half of the term, weekly focus is given to a particular genre, while students try their hands at the designated form. The second half of the term is devoted to in-class workshops, peer critiques and revision of workshop material for the final portfolio. In addition, students meet individually with the teacher for more specific feedback and mentoring. The class culminates in a public reading, showcasing excerpts of student writing to the broader Exeter community. Application Process: Interested students should prepare a work sample of up to 10 pages, in a single genre or multiple genres, and compose a one-page prospectus that details their past experience in creative writing and lays out what they hope to accomplish over the course of the term. *Prerequisite: ENG502, ENG503, ENG512 or permission of the department. Offered: spring term.*

Health and Human Development

The Health and Human Development Department's mission is to prepare and empower students to value and engage in healthy lifestyles by honoring diversity, fostering leadership, and encouraging students to reach their highest potential as productive, responsible citizens at the Academy and beyond. Our courses merge traditional health education pedagogy with the field of positive education, challenging students to stretch their understanding of health issues personally, locally and globally in trusting and respectful environments. While we believe it is important that students have accurate, up-to-date information about health topics, we do not believe that knowledge alone is sufficient for them to make healthful, responsible decisions for themselves and their communities.

In order to facilitate positive healthy choices today and in the future, the curriculum is designed to be developmentally appropriate for each year a student attends PEA and provides opportunities for students to examine their values and attitudes, as well as develop critical thinking, decision making, resiliency, self-advocacy and interpersonal skills.

HHD110/120: TEEN HEALTH MATTERS FOR 9TH GRADERS

In these age-appropriate courses, required of all 9th graders, students will discuss health issues such as sleep, time management, living and learning in a diverse community, mindfulness, positive psychology and stress management, media literacy, and social practices in a digital landscape. All topics will be addressed in the

context of adjusting to a campus community, accessing resources and understanding school rules. We aim to enable students to build self-efficacy and prepare for challenging health and lifestyle choices through the development of effective communication and decision-making skills. The pass/no pass grading system encourages student participation, honesty and sharing in a supportive and more relaxed environment. *Required of all 9th graders. Two single class periods per week in the fall term and two single class periods in the winter or spring, which may include reserve periods.*

HHD210: TEEN HEALTH MATTERS FOR LOWERS

In this age-appropriate course, required of all new lowers, students will discuss health issues such as sleep, time management, living and learning in a diverse community, mindfulness, positive psychology and stress management, media literacy, social practices in a digital landscape, and integrating into their new class. All topics will be addressed in the context of adjusting to a campus community, accessing resources and understanding school rules. We aim to enable students to build self-efficacy and prepare for challenging health and lifestyle choices through the development of effective communication and decision-making skills. The pass/no pass grading system encourages student participation, honesty and sharing in a supportive and more relaxed environment. *Required of all new 10th graders. Two single class periods per week in the fall term, which may include reserve periods.*

HHD240: THRIVING IN COMMUNITY

In this term-long, age-appropriate course, required for all lowers, students will discuss a variety of health issues, such as mental and psychological health, character development, cultural competency, gender, sexuality, consent/healthy relationships, and alcohol/drugs. This course is focused on helping students navigate some of the most common health concerns for their age group. We aim to enable students to build self-efficacy and prepare for challenging health and lifestyle choices. Intentionality is explored throughout the term so that students will develop effective decision-making skills with purpose and thought. With the help of the College Counseling Office, we will explore identity development and self-authorship, foundational aspects to a student's transition from adolescence to young adulthood. The pass/no pass grading system encourages student participation, honesty and sharing in a supportive and more relaxed environment focused around a growth mindset. *Required of all 10th graders. Two single class periods per week in the winter or spring, which may include reserve periods.*

HHD310: TEEN HEALTH MATTERS FOR UPPERS

In this first-term, age-appropriate course, required of all new uppers, students will discuss health issues such as sleep, time management, living and learning in a diverse community, mindfulness, positive psychology and stress management, media literacy, and social practices in a digital landscape. All topics will be addressed in the context of adjusting to a campus community, accessing resources and understanding school rules. Together, all new uppers will explore how to fully integrate into their new class and how to

have a healthy, mindful transition to PEA. A special emphasis on relationships will enable new uppers to build self-efficacy skills and prepare for challenging health and lifestyle choices through in-depth conversations about effective communication and decision-making. The pass/no pass grading system encourages student participation, honesty and sharing in a supportive and more relaxed environment. *Required of all new 11th graders. Two single class periods per week in the fall term, which may include reserve periods.*

HHD340: NAVIGATING HEALTHY CHOICES

Building on skills learned in previous HHD courses, in the upper year students will explore developmentally appropriate topics known to be most influential for navigating their upper year. This course will focus on the most common health issues for their age group, including sexual health, being a bystander, drugs and alcohol, stress management, cultural competency, preparing for senior year, and building life skills that support the development of civilized and engaged community citizens. Throughout the term, self-exploration and empowerment will be encouraged to help students develop greater understanding, deeper self-knowledge and improvement of one's self-image and self-esteem. Students will develop effective communication skills to help them build self-efficacy and resiliency. The pass/no pass grading system encourages student participation, honesty and sharing in a supportive and relaxed environment focused around personal growth. *Required of all 11th graders. Two single class periods per week in the winter or spring, which may include reserve periods. Eleventh graders who are at SYA will be assigned a health educator who acts as an additional resource for the student to strengthen connections back to PEA.*

HHD410: TEEN HEALTH MATTERS FOR SENIORS

In this first-term, age-appropriate course, required of all new seniors and postgraduates, students will discuss health issues such as sleep, time management, living and learning in a diverse community, mindfulness, positive psychology and stress management, media literacy, and social practices in a digital landscape. All topics will be addressed in the context of adjusting to a campus community, accessing resources and understanding school rules. Together, all new seniors will explore how to fully integrate into their new class and how to have a healthy, mindful transition to PEA. A special emphasis on decision-making as they become emerging adults will help students make decisions about their future that offer complexities of choice. In-depth conversations will enable new seniors to build self-efficacy skills and prepare for challenging health and lifestyle choices. The pass/no pass grading system encourages student participation, honesty and sharing in a supportive and more relaxed environment. *Required of all new 12th graders and postgraduates. Two single class periods per week in the fall term, which may include reserve periods.*

HHD490: CROSSROADS: YOUR FUTURE, YOUR HEALTH FOR SENIORS

Seniors have much to look forward to but also have many challenges facing them as they complete their work at PEA. In this seminar-

style course, seniors will have the opportunity to consider common health questions and concerns as they prepare to transition to college or career settings. We will utilize health data as well as students' individual concerns to guide our discussions, seeking guideposts for healthy living in these exciting and challenging times. The course is graded on a pass/no pass basis. *Required of seniors. One class period per week, which may be a reserve format, as well as limited assignments. Offered in spring term. Note: 12th graders who will be enrolled in an off-campus program during the spring term will enroll in HHD490 in the winter term. Twelfth graders who are at SYA will be assigned a health educator who acts as an additional resource for the student to strengthen connections back to PEA.*

HHD502: A STUDY OF HUMAN SEXUALITY

Through reading, research and discussion, students will study the biological, psychological and sociological aspects of human sexuality while considering the political, ethical, legal, historical and cultural forces that shape human sexual behavior. Students will reflect on what is known about sexual functioning and behavior as well as discuss and debate what is not fully understood. *Open to 12th graders. Offered: spring term.*

HHD503: THE POWER WITHIN: PHILOSOPHY & SCIENCE OF OPTIMAL HEALTH

How can we best manage life's competing challenges? How should we measure success? What are the most effective means to enhance one's capabilities, strengths and health status? We will aim to answer these and other questions by studying traditional teachings and practices, as well as the insights and lessons offered by modern-

day behavioral science and neuroscience. Through reading, research, reflection, personal practice and experimentation, students will investigate the theories, models and methods that have proven to enhance well-being. *Open to 11th and 12th graders. Offered: fall term.*

HHD504: THE HUMAN PURSUIT OF EUPHORIA

This course will explore the use of mind-altering substances throughout history, across cultures and within subcultures of the United States. From a biochemical, sociological and psychological standpoint we will probe the reasons why people seek to alter their state of being, whether through the use of drugs or through other means, including meditation, exercise, gaming, shopping and sex. Readings will include selections such as *The Compass of Pleasure* by David Linden; *Flow: The Psychology of Optimal Experience* by Mihaly Csikszentmihalyi; *Forces of Habit* by David Courtwright; *In the Realm of Hungry Ghosts* by Gabor Maté; *High Price* by Carl Hart; and *The Myth of Normal* by Gabor Maté. *Open to 12th graders (11th graders with departmental permission). Offered: winter term.*

History

History faculty members seek to challenge Exeter students to think critically and to write and speak clearly through the study of the historical experience of global communities. Knowledge of the past will allow students to understand the present, to consider their own beliefs and to develop empathy for those different from themselves. Such learning will enable students to lead lives that reflect the values of knowledge and goodness sought in Exeter's founding charter.

History classes rely on evidence-based frameworks for analysis. The department's courses place significant emphasis on teaching students to critically evaluate evidence and sources, using both in-class materials and scholarly research. Nearly all history classes require students to engage in research assignments and research-paper writing, oftentimes focused on the resources available in the Class of 1945 Library. In doing so, the courses aim to introduce students to the complexities of history and the world around them by challenging assumptions,

acknowledging missing or incomplete information, and rewarding the discovery of new topics and perspectives.

Course offerings in the department are open to the following students: 200-level courses are open to 9th graders and also to 10th graders who have not yet taken a 300-level history course at PEA; 300-level courses are open to 10th graders and 11th graders, as well as 9th graders who have already taken a 200-level course; 400-level courses are open to 11th graders and seniors and to 10th graders who have taken a 300-level course; and 500-level courses are open to 11th graders who have taken a 400-level course as well as to seniors and PGs.

Introductory courses, numbered in the 200s, emphasize fundamental skills in the study of history and the social sciences: gathering and interpreting evidence, analyzing concepts, and generalizing and synthesizing in frequent written exercises.

Intermediate courses, numbered in the 300s, utilize more difficult materials, involve the study of more complex concepts and demand a higher level of competence than the 200-level courses.

All introductory and intermediate courses include a library research project, typically culminating in an essay.

Advanced courses are numbered in the 400s, 500s and 600s. The American history sequence — 410, 420 and 430 — is a rigorous, year-long course and is required for the diploma. Each term of the U.S. history sequence includes a significant historical research project and time in the library dedicated to research. The fall term emphasizes how to begin a work of research and culminates in a paper, annotated bibliography or other work. In the winter term, students focus on the library's extensive availability of periodicals, which culminates in a five- to seven-page paper. The research paper in the spring term is expected to be 12 to 15 pages. The 500-level courses are often more topical in nature. Writing assignments and class meetings may be fewer in number than at other levels in order to accommodate more-sophisticated readings. The 600-level courses, in addition to sophisticated readings, require the completion of a significant research paper.

Advanced Placement exams: The department does not confine its teaching to preparing students for standardized tests. We believe that such an approach would compromise our commitment to student-centered discussion, close reading of primary and secondary sources, and independent research and writing. Those students wishing to take AP exams in history are strongly advised to undertake sustained review on their own.

Courses in anthropology and economics are taught under the aegis of the History Department. These courses, however, do not satisfy the history requirement.

Three-year and four-year students are required to take at least one of the following courses: 200, 202, 205, 206, 208, 305, 307, 308, 309, 310, 502, 556, 558, 565, 566, 567, 577, 586 and 587. These courses are marked by ♦ in the individual course descriptions.

■ Introductory Courses

HIS200: THE WORLD IN THE 20TH CENTURY ♦

This course is an introduction to significant events in the 20th century. Students investigate cause, effect and change in places such as Europe, Africa and Asia (including the Middle East). One principal aim of the course is for students to develop a better understanding of the response of traditional societies to the impact of modernization on their values and customs. Another is to examine ideological conflicts of the modern world. Students also research contemporary problems that originated in the 20th century that demand creative and thoughtful solutions. Analytical skills, synthesis of conflicting viewpoints, conducting research in the Academy Library, participating in debates and writing historical essays are all emphasized in this course. *Open to 9th and 10th graders who have not taken a 300-level history course. Offered: fall term.*

HIS202: PEOPLES AND CULTURES OF THE MODERN WORLD ♦

This course examines people who live in the developing world and the impact of modernization and industrialization on their ways of life. Students gain a better understanding of the social, political and economic issues confronting many developing countries today as peasant peoples face and respond to the challenges of the modern institutions and technology. Students are also introduced to the skills necessary for the study of history and the social sciences. This course makes use of the library and engages in a discussion of contemporary social and political events. *Open to 9th and 10th graders who have not taken a 300-level history course. Offered: fall term.*

HIS203: CLASSICAL GREECE

This course examines the archaeology, literature, history and society of the Greek city-states from 1000 to 300 BCE. From Homer and Sappho to texts on the Acropolis in Athens, a variety of materials introduces students to the literature, art, material culture and everyday life of an expansive Greek world. This course encourages students to establish connections between the ancient world and today and question the modern reception of the classical past. It introduces and develops fundamental historical skills, particularly research and writing. *Open to 9th and 10th graders who have not taken a 300-level course. Offered: fall term.*

HIS204: CLASSICAL ROME

This course examines the archaeology, literature, history and society of the Roman world from the foundation of the city through Late Antiquity. Central themes include urbanism, architecture, imperialism, daily life and archaeology. The course introduces and develops fundamental historical skills, particularly writing and research. It encourages students to establish connections between the ancient world and today and question the modern reception of the classical past. *Open to 9th and 10th graders who have not taken a 300-level history course. Offered: winter term.*

HIS205: THE MEDIEVAL WORLDS ♦

In the wake of the fall of the Roman Empire, three distinct and dazzling civilizations emerged. This course examines the creation of the European, Byzantine and Islamic worlds from the end of antiquity to roughly 1350, exploring the political, cultural, social and religious changes in each society. We examine the rise of the Christian Church in Europe and Byzantium, the birth and rapid success of Islam, and the impact on the values and behaviors of medieval people. Key figures, themes and events are studied, including Charlemagne, Muhammad, Justinian, mysticism, scholasticism, the Reconquista and the Crusades. We also discuss how early interactions and conflicts shaped the views each society held of the others. *Open to 9th and 10th graders who have not taken a 300-level course. Offered: spring term.*

HIS206: NATIVE PEOPLES OF THE AMERICAS ♦

This course surveys the history of indigenous groups from their prehistoric roots to the Post-Classic Period. Students gain exposure to anthropological, archaeological and historical resources to illuminate the Mesoamerican societies with a particular focus on the Mayan and Aztec Empires. Students also gain exposure to the evolution of independent cultural and social systems among indigenous tribes in North America. Among the subjects highlighted are the production of foodstuff, evolving patterns of tribal life, governance, warfare and economics. During the latter stages of the course, students examine the ways in which the lives of indigenous peoples were dramatically reconfigured as the economic systems of the Atlantic world forever changed tribal life. *Open to 9th and 10th graders who have not taken a 300-level history course. Offered: spring term.*

HIS208: HISTORY OF JAPAN ♦

This course is an overview of Japanese history and considers how changes in political institutions, economic patterns, social organizations, and cultural practices took shape to transform the lives of individuals across the archipelago. We will explore questions that contemporary scholars grapple with to this day: How did the role of the emperor transform from the 16th to the 18th century? Why is the samurai such a powerful symbol? How did a region poor in resources and largely isolated from the West emerge economically vital in the last hundred years? Why did the concept of progress become such a pivotal concern for the leaders of Meiji Japan in the late 19th century? What are the consequences for rapid industrial revolution? With an emphasis on primary sources, students will analyze this history in terms of those who lived it. We will read from the perspectives of a *daimyo* reformer and a low-ranking *samurai*, from an impoverished farmer and an affluent merchant, the emperor and a housewife. *Open to 9th and 10th graders who have not taken a 300-level history course. Offered: winter term.*

■ Intermediate Courses

HIS302: EARLY MODERN EUROPE, 1350-1660

The centuries following the Black Death saw the beginnings of modern Europe. This course focuses on the rebirth of European society and the new values, optimism and cultural achievements of the Renaissance. It then examines the turbulence of the Reformation — the shattering of Christian unity and the wars fought in the name of religion. The course then explores the development of new politics and the Age of Exploration, when Europeans set sail and changed the shape of the world. *Prerequisite of a 200-level history course. This prerequisite does not apply to new 10th- or 11th-grade students. Twelfth graders may not enroll. Offered: fall term.*

HIS303: ABSOLUTISM AND REVOLUTION, 1660-1800

Beginning with the reign of Louis XIV, students examine 18th-century European society. We explore how the Scientific Revolution and the Enlightenment challenged the ideas of the Old Regime and created new perceptions of humanity, society and government. The

course concludes with an analysis of the French Revolution and the rise of Napoleon. *Prerequisite of a 200-level history course. This prerequisite does not apply to new 10th- or 11th-grade students. Twelfth graders may not enroll. Offered: winter term.*

HIS304: THE EUROPEAN CENTURY, 1800-1914

Beginning with the study of Napoleon's Empire and the Congress of Vienna, this course examines how the French Revolution of 1789 and the Industrial Revolution transformed European society and politics in the 19th century and established Europe's global preeminence. The course concludes with an examination of World War I, the shattering event that culminated Europe's dominance. *Prerequisite of a 200-level history course. This prerequisite does not apply to new 10th- or 11th-grade students. Twelfth graders may not enroll. Offered: spring term.*

HIS305: THE TRANSATLANTIC WORLD: EMPIRE, CONTACT AND LEGACIES ♦

This course examines the imperial interests, race and gender relations, and cultural influences and exchanges that manifested during the era known as Colonial America. Though the course, by the end, focuses on the colonies that would become the United States, it begins with the pre-contact experiences of Native Americans, Africans and Europeans and how their lives eventually converged. Relationships impacted by economic development, racism and religious fervor forged a complex, historical, multiethnic legacy that is still visible today. *Prerequisite of a 200-level history course. This prerequisite does not apply to new 10th- or 11th-grade students. Twelfth graders may not enroll. Offered: spring term.*

HIS307: MODERN INDIA ♦

This course examines the history of what is today the world's largest democracy. It starts in roughly 1700 with a study of the Mughal Empire and its decline, followed by the rise of British India. We explore the East India Company and the impact of British imperialism on India. The 1857 rebellion, the beginning of direct British rule and the consequences of these major events are analyzed. We explore the development and role of the Indian National Congress, explore the emergence of Indian nationalism, and assess Gandhi and other Indian leaders, as well as the forces around independence in 1947. In the last part of the course we study India's identity from independence to today and the current issues and conflicts confronting this increasingly prominent nation. *Prerequisite of a 200-level history course. This prerequisite does not apply to new 10th- or 11th-grade students. Twelfth graders may not enroll. Offered: winter term.*

HIS308: PRECOLONIAL AFRICA ♦

This course introduces students to the complexity and dynamism of the African past, from antiquity to the dawn of the 20th century. The course begins with an examination of the Nile Valley civilizations in antiquity, the historical debates surrounding that era and the advent of Christianity in North Africa. Students then study the rise of Islam in Africa and the West African empires of Ghana, Mali and Songhai. Next, students examine the role played by slavery in the creation of the Atlantic World. The course ends with an analysis of

the dynamics of the cultural clash that ensued from the European colonization of Africa. *Prerequisite of a 200-level history course. This prerequisite does not apply to new 10th- or 11th-grade students. Twelfth graders may not enroll. Offered: fall term.*

HIS309: RACE: A GLOBAL HISTORY ◆

Scientists agree that there are few genetic differences between people of different races and ethnicities. Social scientists thus contend that racial distinctions are a product of society and culture rather than biology. At what point, then, did differences in skin color and other phenotypic traits become significant? This course will explore the history of race and racism by looking at examples across the world. We will consider how humans have been divided into different “groups” and the historical circumstances that have led to those divisions. We will also interrogate the use of scientific theories to justify racism and the more recent repudiation of these theories. Using both primary and secondary sources, students will apply the methods of historical thinking to understand the evolution of racial categories and the impact of history on modern-day issues related to race and ethnicity. *Prerequisite of a 200-level history course. This prerequisite does not apply to new 10th- or 11th-grade students. Twelfth graders may not enroll. Offered: winter term.*

HIS310: HISTORY OF CHINA: QING ◆

This course explores the history of China with a focus on the Qing empire (1636-1912). We explore the expansions and decline of the Qing by looking at the sociopolitical structures, its dramatic clash with European imperialism, patterns of semicolonialism and the formation of the Chinese nationalist movement. HIS310 will tackle questions such as: How can Buddhism, Confucianism and Daoism coexist at the same time? How did the Qing emerge as a multinational, multicultural and multiethnic empire? How did the role of the Qing empire in global history change across the centuries? What makes the Opium Wars (1839-1842, 1856-1860) and the Boxer Rebellion (1899-1901) turning points in modern Chinese history? How did the Qing path to modernization unfold differently from those of other countries in East Asia? How does Chinese society look different from the perspective of a rural female villager versus an emperor? To help us explore how the lived experience of this vast history can vary based on where in China one lived, what role in society one fulfilled and which events one lived through, we will analyze a range of sources, including film, fiction and scholarly assessments. *Prerequisite of a 200-level history course. This prerequisite does not apply to new 10th- or 11th-grade students. Twelfth graders may not enroll. Not open to students who have completed HIS207. Offered: spring term.*

HIS314: ROMAN HISTORY FOR LATIN STUDENTS

This course is typically taken simultaneously with LAT220 and provides a deeper historical background to the world of the authors that students will read in their Latin courses. Beginning with the Roman state and urban formation of the early Iron Age, students will use primary and secondary sources to study a selection of topics from the first millennium BCE in depth. Students will also

read primary sources in the original Latin language and finish the term with a role-playing opportunity examining the collapse of the Roman Republic. *Prerequisite of a 200-level history course and completion of LAT210 or higher (excluding LAT211). The history prerequisite does not apply to new 10th- or 11th-grade students. Twelfth graders may not enroll. Offered: winter term.*

■ Advanced Courses

HIS410: UNITED STATES HISTORY, COLONIAL ORIGINS TO 1861

This course introduces students to the formation of American values and institutions from the early English settlements of North America through the Revolution and Civil War. Emphasis is given to the cultural, economic and social diversity of early America, the tension between local and central authority during the struggle for independence, the establishment of the Constitution, economic and social change in the young republic, slavery, and the growing sectional conflict that culminated in secession. In addition to essays on the course readings, students will complete a library research project. *Prerequisite of a 300-level history course. This prerequisite does not apply to new 11th- or 12th-grade students. Offered: fall term.*

HIS420: UNITED STATES HISTORY, 1861 TO 1941

This course continues the survey of American history with the Civil War and follows with the attempt to rebuild the union during Reconstruction. Emphasis is given to economic and social changes of the late 19th century and the emergence of the United States as a world power. Topics include the transformation of the United States into an urban industrial society, the dilemma of race, the changing role of women, the Depression and the political response to these issues. The course ends with the advent of World War II. In addition to essays on the course readings, students will complete a library research paper. *Prerequisite: HIS410 or equivalent. Offered: winter term.*

HIS430: UNITED STATES HISTORY, 1941 TO THE PRESENT

This course begins with U.S. involvement in World War II. Emphasis is given to the Cold War and rising global involvement of the United States. Other topics include the Civil Rights movement, the social and political turmoil of the 1960s, the dual crises of Vietnam and Watergate, the Reagan revolution and issues of the contemporary world. In addition to essays on the course readings, students will write a significant (12- to 15-page) research paper. *Prerequisite: HIS420 or equivalent. Offered: spring term. A student must pass all three U.S. History courses to satisfy the diploma requirement.*

■ 500- and 600-Level Courses

Some courses numbered in the 500s and 600s may meet just three times per week, as determined by the individual instructor.

HIS502: GLOBAL TOPICS IN WOMEN, GENDER, SEXUALITY AND SOCIETY ◆

In this course, students will examine world historical patterns and processes, with a focus on issues concerning women, gender and sexuality. Students will come to understand how gender and sexuality have been socially and culturally constructed by global historical developments into highly variable and historically changing systems of power relations and have in turn shaped other events and structures. They will evaluate how gender and sexuality intersect with other forms of identity, such as race, class, religion and ethnicity, within political, economic and social systems of power in several 20th- and 21st-century circumstances. This course engages students with complex debates around sex, gender and the body that push beyond binary models reliant on a simple “nature/culture” distinction. Students will also examine the historical development of gay, lesbian and transgender identities and the fight for LGBTQ rights in the 20th and early 21st centuries within the United States, as well as how definitions of LGBTQ identities have been shaped in different time periods and geographical locations. The larger goal is to compare how gender and sexuality distinctions have shaped human experiences across different cultures in the past century. *Open to 11th graders who have taken a 400-level history course and to 12th graders. Offered: fall term.*

HIS503: SEDUCTION AND HORROR: TOTALITARIANISM IN MODERN EUROPE

Why did millions of people enthusiastically accept Hitler, Mussolini and Stalin? This course examines the historic context and rise of totalitarianism in Europe. Central to the story is World War II, the Holocaust and the calculated destruction of millions to secure, according to Mussolini, “everything within the state, nothing outside the state, nothing against the state.” We investigate the floundering of the democracies and the allure of the charismatic leader through the first half of the 20th century. *Open to 11th graders who have taken a 400-level history course and to 12th graders. Offered: fall term.*

HIS504: EUROPE SINCE 1945

In the wake of war and genocide, Europe worked to rebuild and redefine its role in a rapidly shifting world. This course explores Europe’s struggles coming to terms with its multiracial, multireligious and multicultural identity in a new era of uncertainty. We not only study prominent leaders, events and institutions like Thatcher, Gorbachev, the fall of communism and the EU but also view Europe from the perspective of excluded “others.” What lessons, if any, has Europe, a continent with long traditions, vibrant immigrant communities and a resurgent right wing, learned from its violent history and the advent of postcolonialism? *Open to 11th graders who have taken a 400-level history course and to 12th graders. Offered: winter term.*

HIS506: CAPITALISM AND ITS CRITICS

This course provides a survey of the origins and evolution of capitalism in a global world up to the present, with emphasis on the political economies of the West. Students examine the ideas of the great political economists such as Adam Smith, David Ricardo, Thomas Robert Malthus, Karl Marx, J.M. Keynes and Friedrich von Hayek, as well as trace the progression of modern industrial economies in Europe and the United States. The course ends with an analysis of the 2008 financial crisis and the Occupy movement. *Open to 11th graders who have taken a 400-level history course and to 12th graders. Offered: fall term.*

HIS508: UNDERSTANDING VIOLENCE, WAR AND PEACE

This course explores both the history of and theories related to violence, war and peace across the globe, from ancient to modern times. Readings may include selections from a variety of disciplines, such as anthropology, ethics, philosophy, psychology and sociology. Students may consider such questions as: Is there such a thing as a just war? Are humans naturally violent? How do societies avoid violence and maintain peace? What role does technology play in shaping violent behavior? Can justice be achieved through the use of violent means? Is peace a realistic possibility in a globalized world? Is there more to peace than an interim between wars? *Open to 11th graders who have taken a 400-level history course and to 12th graders. Offered: winter term.*

HIS545: BUILDING A MOVEMENT: CIVIL RIGHTS AND BLACK POWER

This course will examine the deep roots of the Civil Rights and Black Power movements. As the historian Keisha Blain has argued, “the fight against racism has always been global.” African Americans have a long history of connecting their freedom struggles to those being waged abroad. We will learn how the Civil Rights and Black Power movements of the post-World War II period built on the foundations of earlier Black internationalist movements and organizations, which laid the intellectual groundwork for the rise of Dr. Martin Luther King Jr., Ella Baker, Malcolm X, and groups like the Student Nonviolent Coordinating Committee and the Black Panther Party. We will study the ideas and contexts that shaped these individuals and organizations, learning about grassroots activists at the local level and “bourgeois radicals,” who fought to harness the power of the United Nations in the fight against racial terrorism in the U.S. This course will examine the possibilities and challenges faced by African American activists working within the Civil Rights, nation-state framework, and the myriad efforts to build broader transnational movements. *Open to 11th graders who have taken a 400-level history course and to 12th graders. Not offered 2026-27.*

HIS550: AMERICAN POLITICS AND PUBLIC POLICY

This course introduces students to the unique process by which American governments develop policies to address the nation’s most significant problems. In addition to studying specific policy issues, students will read about Congress and the presidency, political parties, elections, ideologies, the role of media and the psychology

of politics. Each student will research one policy issue and make a formal presentation to the class. This course may incorporate a service-learning component as an aspect of the final project. *This course does not fulfill a history diploma requirement for three- and four-year students. Open to 11th graders who have taken a 400-level history course and to 12th graders. Offered: fall term.*

HIS553: LAW AND AMERICAN SOCIETY

This course provides students with an introduction to the American legal system and to the development of American constitutional law. Historic Supreme Court decisions and legal case studies will be used to develop an in-depth understanding of the historical background and present-day constitutional controversies over such topics as free speech, censorship, abortion, workplace discrimination, affirmative action and the rights of the accused. Practitioners from the fields of law and criminal justice may provide an added dimension to the course. *This course does not fulfill a history diploma requirement for three- and four-year students. Open to 11th graders who have taken a 400-level history course and to 12th graders. Offered: spring term.*

HIS554: REVOLUTIONARY RUSSIA

This course examines Russian history from the Decembrist uprising of 1825 to Stalin and the destruction of the Old Bolsheviks in the late 1930s. After a brief survey of autocracy and orthodoxy in Old Russia and westernization under Peter the Great, students focus on the 19th and early 20th centuries, with emphasis on the development of the revolutionary tradition, the rise of the intelligentsia, the Bolshevik Revolution and Civil War, Marxist theory, Lenin's rule and Stalin's dictatorship. Special attention is given to Russian literature, with works by Pushkin, Gogol, Turgenev, Dostoyevsky and Tolstoy. *Open to 11th graders who have taken a 400-level history course and to 12th graders. Offered: winter term.*

HIS556: WHY ARE POOR NATIONS POOR? ♦

This course will examine the plight of developing nations. Students will explore why the quality of life of these countries' citizens remains, in the aggregate, so low and their choices so limited. Topics to be considered include the historical legacy of colonization, cultural and social issues, geography and climate, agriculture and famine, human capital, governance and corruption, and foreign aid, debt and trade. Case studies will be examined comparing various nations in Latin America, Africa and Asia. *Open to 11th graders who have taken a 400-level history course and to 12th graders. Offered: winter term.*

HIS558: GENOCIDE IN THE MODERN WORLD ♦

This course studies the history of genocide in the 20th and 21st centuries, exploring both the patterns and unique circumstances of this important global issue. Students read and hear from historians, victims and perpetrators. Likely case studies are the Holocaust, Cambodia, the Balkans, and Rwanda, with time set aside for research into events determined by student interest. Students study root causes, including economic, political and social factors that permit the occurrence of genocide; assess international responses; and evaluate attempts at reconciliation, including justice systems

and community reactions. The comparative nature of the course creates a framework to draw broad lessons about what leads to genocide in the modern world; enables us to assess the behavior, actions and inaction of the various groups involved; and pushes us to consider how these lessons could be applied to prevent such crimes in the future. *Open to 11th graders who have taken a 400-level history course and to 12th graders. Offered: spring term.*

HIS563: HUMANS AND THE ENVIRONMENT

What drives human history? Do the pivotal factors lie beyond human control, such as climate, geography, ecosystems and microbes? This course examines the interactions between people and the natural world over time. In struggling to master an often hostile environment, human societies have had an ever-increasing impact on the planet, and apparent success has often ended in failure. The course begins with the emergence of humans in the Paleolithic period and then explores the invention of agriculture, the emergence of global trade and migration networks, colonialism and the Industrial Revolution. Students examine in depth one instance of humans managing — or mismanaging — a natural resource and conclude the course with a close look at 20th-century trends and the future we collectively face. *Open to 11th graders who have taken a 400-level history course and to 12th graders. Offered: fall term.*

HIS565: MODERN CHINA ♦

This course examines China's dramatic recent history through multiple lenses: historical survey, biography, memoir, film and journalism. We begin by identifying key themes and questions to guide our study. Then we move back in time to the 19th century, when contact with Westerners provoked war and internal rebellions. We examine the decline and eventual collapse of the imperial dynastic system, the rise of warlordism, an experiment in weak republican government, the prolonged civil war, China's role in World War II, the founding of the People's Republic, the thought and governance of Mao Zedong, the economic and social reforms of Deng Xiaoping, and China's entry into the global marketplace. The last part of the course utilizes a variety of current sources to address the major issues facing China in the 21st century. *Open to 11th graders who have taken a 400-level history course and to 12th graders. Offered: winter term.*

HIS566: MODERN LATIN AMERICA ♦

This course examines how modern social and political institutions developed in the region that includes Central and South America and the Caribbean. We begin by questioning why such diverse places are imagined as a single region. We explore how colonialism shaped the region and how independent nations emerged from European political control in the early 19th century. Through a series of case studies, we then examine selected social, political and economic issues that shaped Latin America in the 19th and 20th centuries. *Open to 11th graders who have taken a 400-level history course and to 12th graders. Offered: spring term.*

HIS567: MODERN ASIA: CONTESTED HISTORIES ◆

How and why do different national histories define themselves in competition with those of their neighbors? This course will focus on how recent trends in the writing of history are applied to the context of contemporary Asia including China, India, Indonesia, Japan, Korea, Thailand and Vietnam. These topics will be explored through a range of sources including film, memoirs, fiction, periodicals and scholarly assessments that reflect the diversity of experiences across Asia. Topics will include Marxist history, cultural history, gender, memory, modernity and ethnicity. This course will rely on students to conduct independent research throughout the term in digging through contested topics and historical controversies, including but not limited to competing national histories of imperialism, colonization, and nationhood in the 20th century. *Open to 11th graders who have taken a 400-level history course and to 12th graders. Offered: fall term.*

HIS568: HISTORY THROUGH FOOD ◆

From the Neolithic Revolution through the emergence of the global food markets of the 20th century, this course examines the changing relationship between humans and food. Through a combination of readings, tastings and hands-on cooking, we will examine how food can help us understand various aspects of the past around the world. Topics include the relationship between food and the economy, food and identity, food and empire, and food and the environment. Come hungry to learn and to eat. We will be reading about, writing about, cooking and tasting food that can help us understand how humans shape what they eat and how what we eat shapes us. *Open to 12th graders who have taken HIS430 or equivalent. Students must complete an application for this course. This course meets during the reserve format in order to create a double-format meeting time for meal preparation. Offered: spring term.*

HIS577: A HISTORY OF MODERN AFRICA ◆

What do we mean by “modern,” and what does “modern Africa” look like? The story of modernity has often been told from a Eurocentric perspective — one that conveniently excludes Africa. In this course, we will investigate the ways in which Africa is tied to modernity and the world. Chronologically, the course will investigate the continent’s history, beginning with the abolition of slave trade; 19th-century imperialism and the “scramble” for the continent; anti-colonial movements and decolonization; as well as the post-independence social and political realities. For the most part, academic study of Africa in the Global North has been dominated by non-Africans. Alternatively, in this course, we re-center African voices — that is, scholarly, literary and political writings of notable Africans to help students challenge the conventional wisdom about the rise of the modern world and the role of Africa in the global arena. *Open to 11th graders who have taken a 400-level history course and to 12th graders. Offered: winter term.*

HIS586: CONTEMPORARY MIDDLE EAST ◆

The course begins with the breakup of the Ottoman Empire and examines the rise of Arab nationalism and the struggle against

foreign domination. The strategic and economic importance of the region is studied along with the founding of Israel; the continuing conflict among Jews, Arabs, and Christians; and the rise of Islamic fundamentalism. Particular emphasis is placed on understanding the Arab-Israeli conflict. *Open to 11th graders who have taken a 400-level history course and to 12th graders. Offered: fall term.*

HIS587: SALEM WITCH TRIALS: A GLOBAL HISTORY OF WITCHCRAFT ◆

Witchcraft is popularly viewed as spells cast by witches who freely practice them. Others believe that witchcraft is part of an old-world order long replaced by the modern world. Yet witchcraft is alive and well across the globe. This course offers a global history of witchcraft, understanding that witchcraft and its accusations are a means to regulate behavior through processes of socialization. Historically speaking, this process has proven deadly, targeting women or those socially ostracized by societies. Utilizing the wealth of scholarship and primary sources related to the Salem witch trials of 1692, this course explores the political, religious, gender and economic drivers of these trials. Students gain knowledge of events using the Salem Witch Trials Documentary Archive and Transcription Project at the University of Virginia to explore the intricacies associated with the trials. From this case study, the course turns to a global examination of witch accusations from the ancient to the modern world. During the course students encounter many topics, including notions of magic versus religion; social power and judicial authority; typologies; gender stereotypes; culturally constructed concepts of “deviance” and “pollution”; and mental illness. *Open to 11th graders who have taken a 400-level history course and to 12th graders. Offered: spring term.*

HIS590: DICTATORS AND DEMAGOGUES IN 20TH-CENTURY WORLD HISTORY ◆

Beginning in the European interwar period and ending with the collapse of the Cold War, this course explores the origins of authoritarian and totalitarian regimes in 20th-century world history. We begin by identifying key theories and questions and then move chronologically and by region to understand a wide range of illiberal regimes in Europe, Latin America, Asia and Africa. Through a mix of scholarly readings, primary sources and comparative analysis, we will investigate how economic ambitions, nationalist visions, ethnic politics and political ideologies shaped the evolution of these regimes. By the end of the course, we will be able to explain what makes a society susceptible to authoritarianism; analyze how tools such as propaganda, personality cults, bureaucratic expansion and state violence help autocrats build and maintain control; and develop nuanced arguments about the forces that shape political authority in the modern world. *Open to 11th graders who have taken a 400-level history course and to 12th graders. Offered: winter term.*

HIS602: PROBLEMS IN ANCIENT MEDITERRANEAN HISTORY

This course aims to provide broad exposure to several approaches to the study of Mediterranean history. Each year will be centered around a particular topic. This topic may be thematic (such as the ancient economy, ethnicity in the ancient Mediterranean) or

rooted in an institution, time or place (such as Athenian democracy, Augustan propaganda, the Social War). We will gain an understanding of the primary source evidence (textual, numismatic, epigraphic, archaeological and art historical, to name a few categories) and historiography related to the topic to craft a symposium of research presentations around the theme at the end of the term. In doing so, students will be entering a conversation with other scholars that explores a diversity of people, places, political systems, social structures and time periods quite different from our own, yet whose study raises questions that echo questions prevalent in the modern world. In addition to reading and essay assignments, students will spend a significant amount of course time conducting research with the goal of producing a 10- to 20-page essay and participating in a symposium in the second half of the term. *Open to 11th and 12th graders who have taken HIS430 or equivalent. Offered: fall term.*

Integrated Studies

In the words of biologist E.O. Wilson, “We are drowning in information, while starving for wisdom. The world henceforth will be run by synthesizers, people able to put together the right information at the right time, think critically about it, and make important choices wisely.” Integrated studies courses are positioned in this aspirational space, encouraging students to make connections across disciplinary lines and utilize skills they have developed in different disciplines.

INT455: PRINCIPLES OF ENGINEERING AND DESIGN

This course will explore the principles of engineering and design in a hands-on, project-oriented environment using the tools and materials in the Design Lab. Students will investigate the nature of materials, learn the processes used to form them, and develop the skills needed to communicate design intent to manufacturers. They will absorb the language of design through mechanical dissection and reverse engineering and critically discuss the strengths and weaknesses of manufactured products. Through hand-sketching, engineering drawings and computer-aided design, students will express design intent while using the engineering process to formulate solutions to real-world engineering challenges. What does it mean to make a good object? What are the responsibilities that come with shaping our material space? How can we design and build for a better future? These questions allow us to investigate and discuss the role of the engineer in modern society. *Prerequisite: one year of introductory physics. Open to 11th and 12th graders. Offered: fall term.*

INT503: THE WORLD SEEN THROUGH A DAILY NEWSPAPER

This course affords students the opportunity to spend a term delving into the world’s current events through an intensive reading of *The New York Times*. Over the course of the term, students will track

various geopolitical, economic and social issues as they are reported in the newspaper. Through careful consideration of how the paper reports on and develops the issues followed, students will gain an in-depth understanding of our world while honing their news-literacy skills. Class time is devoted to collective analysis of these issues and to discussion of whatever stories appear in the newspaper on a given day. Occasional background materials are provided by the instructor to help students place daily events in a larger historical context. *Open to 12th graders. Offered: spring term.*

INT504: HUMAN RIGHTS

“An injustice committed against anyone is a threat to everyone.”
— Montesquieu

In this course we will examine the origins of ideas about human rights as well as those documents, such as the Universal Declaration of Human Rights, that define contemporary understanding of those rights that assure freedom, dignity and respect for each human being. We will examine United Nations human rights legislation as well as organizations such as Human Rights Watch and Amnesty International, whose work is dedicated to protecting the rights of people around the world. Our work will include case studies and examination of one or more civil and political rights (for example, children’s rights, freedom of speech rights, torture and prisoners’ rights), and at least one socioeconomic or cultural right (for example water, education or the environment). We may also study genocides of the 20th and 21st centuries in places like Rwanda and Darfur. Reading for the course will include Samantha Power’s *A Problem from Hell: America and the Age of Genocide*, as well as material particular to the various case studies and documents that make up the course. Films and outside speakers will provide additional resources for our study. *Open to 12th graders. Offered: spring term.*

INT508: A STUDY OF SPORT IN SOCIETY

This course will examine the influence of sport on our contemporary global society. Exploring issues of race, class, education, coaching, gender and the overall impact of the multibillion-dollar industry sport has become, the course will draw on the fields of sociology, psychology and history. Resources will include guest speakers, movies, podcasts, articles and texts, including *Loving Sports When They Don't Love You Back: Dilemmas of the Modern Fan*. The course will also incorporate new and relevant excerpts from additional works that address current issues and evolving debates in the world of sport. *This course does not meet the physical education requirement. Open to 12th graders. Offered: spring term.*

INT515: WAR, IDENTITY AND NATIONHOOD OF THE UNITED STATES

We will explore how identity and nationality are both created and challenged through the writing that happens around war. Beginning with a focus on U.S. involvement in Southeast Asia during the mid-20th century and tracing the evolution of foreign policy to the Middle East in the 21st century, we will explore various influences — both external and internal — that inform U.S. policy. Our investigation of literature, historical documents and art will prompt us to examine the way war is constructed and explained versus the way war is remembered. We will explore the relationship between individual memories and collective memories; how individual narratives come to stand for or lie in contrast to national narratives; and how the memories of different groups can be brought together under an idea, a nationality. How do stories that dominated public imagination in the U.S. compare with individuals' stories, both at home and abroad, and how were these identities challenged or redefined by U.S. involvement? How does the U.S. government's presentation of events compare with the way people experienced and perceived these same events? The course will culminate in a writing project that joins historical research, literary analysis and personal experience. *Open to 11th and 12th graders. If eligible, students may choose an English or history diploma credit. A history diploma credit may be earned only by students who received a U.S. history waiver and consulted the History Department chair. Twelfth graders can earn a diploma credit for a 500-level English course. Offered: spring term.*

INT519: GREEN UMBRELLA LEARNING LAB (GULL)

Sustainability thinker and Oberlin College professor David Orr stated that “big changes start in places small enough to be innovative and agile, but large enough to be important.” This course affords students passionate about sustainability the opportunity to develop sustainability-focused projects on campus that align with Exeter's environmental goals, as articulated in PEA's Climate Action Plan. Students will work closely with their instructor to research, design and implement relevant campus sustainability projects that benefit the community. Students will engage with experiential and interdisciplinary problem-solving. If, for example, students would like to study campus renewable energy use, then they would work closely to craft a regimen of supplementary readings, conversations, research, site visits, and anything that might inform

students' projects and provide context. Students will keep a detailed reflective journal about their work, submit a thorough project self-reflection, and give a formal demonstration of learning to a panel of community members. *This course meets during a reserve format in order to create a double-format meeting time for weekly labs. Open to 11th and 12th graders. Offered: winter term.*

INT540: PERFORMANCE AND THE BRAIN

This course provides students with insights into mental skills essential for performance in sports, academics and business. Brain training is a central focus, playing a vital role in enhancing performance and personal growth, making it an indispensable part of the curriculum. The course emphasizes the practical application of mental techniques in real-world settings, exploring the experiences of professional athletes, artists, business leaders and adventurers to uncover the secrets of optimal performance. Students will read *The Willpower Instinct and Atomic Habits*, along with supplemental articles, to support their learning. *Open to 11th and 12th graders. Offered: fall term.*

INT545: THE INTERSECTION OF SCIENCE, HEALTH AND RACE IN AMERICA

In her book *Fatal Invention*, Dorothy Roberts describes race as a political construct disguised as biological that results in lasting health-related consequences, especially for African Americans in the United States. Informed by this idea, this team-taught interdisciplinary course explores the historical and contemporary implications of race and racism in science and medicine as experienced by African Americans. We utilize sociological, historical and scientific theoretical frameworks to dig deep into the physical and real-life health and wellness impacts of structural, race-based social inequality. The main course objectives are: to give students a better understanding of the impact of race on health by exposing how environments and social structures cause racial stress and deleterious physiological outcomes; to learn about historical medical abuse that has led to a mistrust of doctors and less frequent access to medicine; and to explore and discredit modern myths and the medical methodology guided by those myths that result in higher mortality rates for African Americans. To achieve these objectives, students will explore institutional archives, participate in and offer interpretation of lab exercises, lead and participate in Harkness discussions, conduct independent research projects, and share information learned with their peers. *Open to 11th and 12th graders. Prerequisite of one year of biology and one year of U.S. history. Students earn a biological science diploma credit. Not offered in 2026-27.*

INT550: SPORTS SCIENCE

Sports Science explores how the body works during exercise and athletic performance. This course is for students interested in developing a better understanding of the science behind performance enhancement. The course examines muscle function and development at the cellular level and explains how the body's energy systems respond to the demands of sport and exercise. Each week, students will participate in physical testing protocols

to analyze muscle fiber types, lactate threshold, VO2 max and anaerobic power. The discussion-based portion of the course includes readings from *The Sports Gene*, supplemental articles and the *Exercise Physiology* textbook. This course blends hands-on experiential learning with Harkness-style discussions. *This course does not meet the physical education requirement. Open to 12th graders. Offered: spring term.*

INT552: SCIENCE, TECHNOLOGY AND PROFIT IN SOCIETIES

In this course we will examine the interrelation of science and social progress. As we will see, legal and governing systems are inextricably linked to scientific progress, and science is a catalyst for social change. Profit and fortune seeking is a common denominator to both. We will examine cases of this relation in a wide range of time and places: from Mesopotamia to Silicon Valley. It is hoped that this survey of ideas and events will serve the students as a springboard for thought and action when in college and later in their working lives. Texts will include *The Day the Universe Changed* by James Burke; *Guns, Germs, and Steel* by Jared Diamond; *Galileo's Revenge: Junk Science in the Courtroom* by Peter Huber; and *The Economy of Europe in an Age of Crisis* by Jan de Vries. Part of the course will be reading and relevant videos, and part will be student presentations and student-directed discussion. *Prerequisite: two years of lab science. Open to 12th graders. Offered: spring term.*

INT553: SOCIAL INNOVATION

Social innovation is often defined as the creative pursuit of solutions to social or environmental problems. In this course, students will spend the first half of the term exploring and discussing case studies of social innovation projects. These case studies, along with texts like *The Field Guide to Human Centered-Design* by IDEO.org and *Creativity Rules: Get Ideas Out of Your Head and Into the World* by Tina Seelig, will provide us with a working vocabulary for creative problem-solving methodologies and a historical understanding of successful endeavors from the past. The second half of the course will be devoted to student-designed group projects that tackle real-world problems. Groups will share their progress and elicit feedback from the full group through periodic presentations and reports. The class will operate at this stage as a laboratory for collaborative problem solving and will explore the range of strategies that can be used to tackle what social planners refer to as “wicked problems.” *Open to 12th graders. Offered: fall term.*

INT554: DESIGN THINKING: CREATIVE PROBLEM-SOLVING WORKSHOP

Design thinking is a problem-solving process that has led to many innovations in fields ranging from medical products, to engineering, to education, and even to children's toys. Some of the key ideas within the method are designing with a human-centered approach, using prototypes to facilitate design decisions, and embracing design refinements based on feedback. Students at Stanford, a leader in design thinking, used the method to design a low-cost infant warmer that reduces infant mortality in developing

countries. Other students have created products featured on Kickstarter, such as a self-watering kitchen garden and a reinvented bicycle bell. At the start of the term, students in this class will learn about and apply each of the aspects of design thinking in a series of small projects in which they will work together to create solutions to real-world needs and problems. These projects will ask students to interview others to learn of their needs; to ideate with their peers to identify possible solutions; to build prototypes early and often; and to incorporate feedback to improve their design solutions. Tools and materials appropriate to making prototypes will be available. *Open to 12th graders. Offered: spring term.*

INT579: BIOETHICS

Our ability to alter the world at the biological level has risen to new heights, and discussions about the ethical implications of these advancements are essential. Between advanced technologies, such as gene editing, cloning and stem cell research, and advanced medical procedures, such as IVF, organ donation, vaccination and gene therapy, individuals and societies are faced with moral questions about how to utilize these things in morally permissible ways. What is the right thing to do? What is worth the most time, effort and resources? Are certain groups impacted differently than others? What are our obligations to each other, and what are the moral underpinnings of our decisions? Bioethics is a team-taught course given by a religion, ethics and philosophy teacher and a biology teacher that dives into these significant questions. A study of moral principles, theories and arguments will give us the framework we need for ethical discussions throughout the term. Not only will we discuss the ethics of several biological techniques, but we will also learn the advanced biology involved and will spend time in the lab performing some of these techniques ourselves; for example, we will use the CRISPR/Cas 9 system to do gene editing. *Prerequisite: one year of introductory biology. Students may choose to take the course for either a biological science credit or a religion, ethics and philosophy credit. Open to 11th and 12th graders. Offered: fall term.*

INT585: READING THE CITY: AN INTRODUCTION TO URBAN STUDIES

The world's urban populations rose from 13% in 1900 to 56.61% in 2021. Attendant to this global trend are the ongoing pressures on urban and national governments to provide solutions to a wide array of urban problems. This course is about how cities, suburbs and metropolitan areas worldwide meet, or fall short of, the residents' aspirations to address those problems. The course will use the tools of geography, history and social sciences to get a sense of how various disciplines frame and analyze the urban question. As this course requires hands-on student involvement, field trips and short assignments culminating in a final project will constitute opportunities for students to learn and use new skills in “reading” the city. The course is divided into three main *topoi* (spatial contexts), each associated with a set of concepts, theories, processes and issues. First is the *local*, where Exeter will serve as a visual laboratory for analyzing spatial data. Second is the *national*, with Boston serving as a case study in urban history and a potential site for ethnographic exploration. And third, the *global* will focus on

a selection of cities in the Global South to exemplify ways in which (post)colonialism, global capitalism and state formation continue to (re)shape urban processes. *The course will include three Sunday field trips to Boston. Each student must commit to attending at least two of these trips. Release time will be given but may not be commensurate with field trip hours. Prerequisite: HIS430 or equivalent. Open to 11th and 12th graders. Students earn a history diploma credit. Offered: spring term.*

Exeter Innovation

The Academy created Exeter Innovation courses to experiment and promote creativity across all disciplines. By design, these experiential opportunities embrace the confluence of classroom learning at the Harkness table and the meaningful learning experiences in co- and extracurricular activities.

EXI306: JUDE HALL HOMESTEAD ARCHAEOLOGY EXCAVATION

This is an immersive, active learning course that takes place both in the classroom and out in the field. The course combines Harkness work around the table with Harkness in the field, namely a student-driven archaeology excavation of the Jude Hall Homestead. Located near Jude's Pond, the remains of the homestead were discovered in 2023. The excavation of this site will illuminate the life of the Hall Family, which is one of the earliest Black families in Exeter, NH. Jude Hall was a veteran of the Revolutionary War, serving from 1775 to 1783, and Moses Uriah Hall, the grandson of Jude Hall, was the first Black student to attend the Academy in 1858. We will also explore the history of Phillips Exeter Academy and greater New England during the Revolutionary Period, Middle Period (antebellum) and Civil War through the land that it occupies. This is an experiential class where students learn about the history of the Academy through unearthing it themselves. *Open to 10th graders who have taken a 200-level history course. Students must complete an application for this course. Students will earn a history diploma credit by passing this course. This course meets during the reserve format in order to create a double-format meeting time for weekly field work. Offered: spring term.*

EXI403: UNDERSTANDING AND CODING MODERN ENCRYPTION SCHEMES

Data encryption is both an ancient and current field of inquiry, and one that underpins almost all modern e-commerce and digital communication. Understanding today's encryption schemes means understanding both important ideas in Number Theory and fundamental ideas of programming and computer science. In this course, students will learn the history of encryption schemes and enough math to understand the RSA encryption scheme. Students will also improve their coding skills to be able to code the schemes studied and understand how the limits of today's computers ensure the safety of our data. Finally, students will develop an understanding of why elliptic curves are better than integers for encryption and how quantum computing would impact our current systems. *Prerequisite: any Exeter computer science course and MAT330 (or its equivalent) or permission of the department. Offered: fall term.*

EXI506: THE ART OF SLOWING DOWN: ATTENTION, CENTERING AND STILLNESS IN THE CREATIVE PROCESS

In this transdisciplinary course, students will encounter creative writing practices alongside practices of stillness, contemplation and presence rooted in diverse religious, philosophical and humanistic traditions. During the term, students will familiarize themselves with practices arising from traditions of stillness and slowness as a way into their creative writing process. Students will engage weekly in the artistic practices of attention fostered by Peter Elbow, Gabriele Rico, Marilyn Nelson, Ross Gay and others in the form of journaling, clustering and free-writing, and they will keep an ongoing notebook as a living artifact of their creative and intellectual exploration. These creative practices are designed to help record the thought process and encourage right-brain, associative movement and connections, which are extremely fruitful in creative writing. Alongside these regular creative practices, students may encounter the engaged Buddhism of Thich Nhat Hanh and the mindfulness practices of Plum Village in conversation with the Christian mysticism of Julian of Norwich and philosophies and practices from the yogic tradition (drawing from texts and teachings such as the Hatha Yoga Pradipika of Yogi Swami Swatmarama and the Yoga Suktas of Patanjali). By experiencing practices of stillness, contemplation and presence, students will start to discover what becomes possible artistically when one slows down, takes time and becomes mindful as writers, readers, thinkers and human beings. Course assignments will be likewise process-oriented with small and regular artistic prompts to foster the creative possibilities that arise through coordinate "musings" (Marilyn Nelson) at the Harkness table and on the page. *Open to 11th and 12th graders. Twelfth graders can earn a diploma credit for a 500-level English course. Offered: spring term.*

EXI507: GOOD GRIEF: GAINING KNOWLEDGE AND LEARNING SKILLS TO NAVIGATE GRIEF AND LOSS IN LIFE

All human beings experience loss. Whether the end of a close friendship, a personal disappointment or the death of a loved one, we all must navigate the grief that accompanies the inevitable losses in our lives. In this unique interdisciplinary elective, students will develop their own intellectual, experiential and personal understandings of grief and loss, death and mourning. Using developmentally appropriate entry points, students will learn about a range of psychological, social/emotional, cultural, spiritual, and behavioral responses and rituals. Students will explore core concepts through: 1) readings about the psychology, history and rituals of loss and grief, including a range of universal and particularistic aspects of death and mourning; 2) guest lectures by scholars in the field and field trips to local institutions; and 3) analysis of current practices and expressions of grief and loss in our popular culture, as seen in social media, film, music and literature. The course will culminate in individual student projects that express a student's unique understanding of the complexities of navigating loss, experiencing grief, and understanding death and mourning. *Open to 11th and 12th graders. Offered: winter term.*

EXI513: CIVIL WAR TRAVEL SEMINAR AND DOCUMENTARY FILM PROJECT: A PEOPLE'S CONTEST

During a weeklong class trip over spring break, students will explore the American Civil War and Reconstruction periods through traveling to historic sites, doing fieldwork and conducting onsite archival research. While visiting these historic sites, students will talk with scholars in the field, collect documentary information related to PEA alumni who fought in the American Civil War and walk some of the same historic terrain as these soldiers. Among the sites visited are the Harriet Tubman Museum and Educational Center, the Antietam and Gettysburg Battlefields, the David Will House, Harpers Ferry, John Brown's Headquarters, the National Museum of Civil War Medicine, and regional archives such as the National Archives in Washington, D.C.

Upon returning to the classroom for the spring term, students will continue to read about the war and Reconstruction, while developing written and visual materials ultimately related to the production of a short documentary film focusing on the life of a PEA alum who fought in the war. To help facilitate this process, students will have the unique opportunity to discuss their work and research with the Emmy Award-winning filmmaker and PEA alumna Julie A. Dunfee. Ms. Dunfee will serve as a periodic instructor in the course, helping students to understand and represent the past through the visual medium of film. Students enrolled in the course must commit to attending the weeklong off-campus trip during spring break. The trip will be fully funded by the Academy. *Open to 11th graders who have taken a 400-level history course and to 12th graders. Offered: spring term.*

Mathematics

The goal of the Mathematics Department is that all of our students understand and appreciate the mathematics they are studying; that they can read it, write it, explore it and communicate it with confidence; and that they will be able to use mathematics as they need to in their lives.

We believe that problem solving (investigating, conjecturing, predicting, analyzing, and verifying), followed by a well-reasoned presentation of results, is central to the process of learning mathematics, and that this learning happens most effectively in a cooperative, student-centered classroom.

We see the following tenets as fundamental to our curriculum:

- › that algebra is important as a modeling and problem-solving tool, with sufficient emphasis placed on technical facility to allow conceptual understanding;
- › that geometry in two and three dimensions be integrated across topics at all levels and include coordinate and transformational approaches;
- › that the study of vectors, matrices, counting, data analysis and other topics from discrete mathematics be woven into core courses;
- › that computer-based and calculator-based activities be part of our courses;
- › that all topics be explored visually, symbolically and verbally;
- › that developing problem-solving strategies depends on an accumulated body of knowledge.

Our intention is to have students assume responsibility for the mathematics they explore — to understand theorems that are developed, to be able to use techniques appropriately, to know how to test results for reasonability, to learn to use technology appropriately and to welcome new challenges whose outcomes are unknown.

To implement this educational philosophy, members of the PEA Mathematics Department have composed problems for nearly every course that we offer. The problems require that students read carefully, as all pertinent information is contained within the text of the problems themselves — there is no external annotation. The resulting curriculum is problem-centered rather than topic-centered. The purpose of this format is to have students continually encounter mathematics set in meaningful contexts, enabling them to draw, and then verify, their own conclusions.

As in most Academy classes, mathematics is studied seminar-style, with students and instructor seated around a large table. This pedagogy demands that students be active contributors in class each day; they are expected to ask questions, to share their results with their classmates and to be prime movers of each day's investigations. The benefit of such participation in the students' study of mathematics is an enhanced ability to ask effective questions, to answer fellow students' inquiries, and to critically assess and present their own work. The goal is that the students, not the teacher or a textbook, be the source of mathematical knowledge.

Note: Math courses through MAT310/311, MAT320, MAT330, MAT400, MAT410, MAT420, MAT430, MAT510, MAT520, MAT41C, MAT42C, MAT43C, and most Transition Mathematics courses, meet during some or all of the reserve formats, thus meeting approximately five to 10 more times per term than other courses.

The Mathematics Department at Exeter believes that technology can have a positive effect on mathematics classrooms and curricula. While we encourage the use of different forms of technology, we do not require students to purchase a handheld graphing calculator. If students do wish to purchase a calculator to support their work, we suggest that they read through the list of allowed devices on the various standardized testing websites before choosing which to purchase.

■ Transition Mathematics

In order to merge new students into our mathematics program, we offer transitional courses to help students adjust to seminar-table methodology and our problem-based curriculum, and to fill gaps and cope with varied backgrounds. This is necessary because:

- › Our precalculus offerings are integrated across the standard boundaries of algebra, geometry and trigonometry;
- › Much of the content of our courses is nontraditional;
- › Word problems are the foundation of our curriculum.

Introductory courses give students and instructors additional information to determine placement for the following term. Typically, transitional courses last one term, but some extend for two or even three terms. Initial course assignments are determined by the department's committee on placement after reviewing each student's academic background, performance on placement tests, scores on standardized tests, and responses to a mathematics questionnaire completed after acceptance.

■ Transition 1 Mathematics

This transition option is for students with algebra experience, but little or no background in geometry. Students are placed in one of the following three courses in the fall term.

MAT11T provides an in-depth three-term algebra sequence. Students who start in MAT11T will move through MAT11T/MAT120/MAT130 in their first year. *Meets during the reserve format.*

MAT12T enables students to study two terms of algebra to enhance their skills. Students who start in MAT12T will move through either MAT12T/MAT120/MAT130 or MAT12T/MAT130/MAT210 in their first year. *Meets during the reserve format.*

MAT13T provides a one-term opportunity for students to review and improve their algebra skills. Students who start in MAT13T will move through either MAT13T/MAT130/MAT210 or MAT13T/MAT210/MAT220 in their first year. *Meets during the reserve format.*

■ Transition 2 Mathematics

This transition option is for students with one or more years of algebra and one full year of geometry. Similar to the 200-level courses, these courses feature the study of geometry tied to algebra processes. Depending on their academic backgrounds, students are placed in one of the following three courses during the fall term.

MAT21T is for students who will benefit from some algebra review as well as two or three terms of Math 2. Students who start in MAT21T will move through either MAT21T/MAT210/MAT220; MAT21T/MAT220/MAT230; or MAT21T/MAT23X/MAT310 (or MAT311) in their first year. *Meets during the reserve format.*

MAT22T enables students to study two or three terms of Math 2. Students who start in MAT22T will move through either MAT22T/MAT220/MAT230 or MAT22T/MAT230/MAT310 (or MAT311) in their first year. *Meets during the reserve format.*

MAT23X is an accelerated course for students needing one or two terms of Math 2. Students who start in MAT23X will move through either MAT23X/MAT230/MAT310 (or MAT311); MAT23X/MAT310/MAT320; MAT23X/MAT311/MAT321; or MAT23X/MAT32X/MAT40X in their first year. *Meets during the reserve format.*

■ Transition 3 Mathematics

This option provides a two- or three-term transition for students with three full years of high school mathematics. MAT31T and MAT34T are primarily for entering uppers.

MAT31T/32T provides a two-term transition into our 300-level courses (advanced integrated mathematics). Students who start in MAT31T often move through MAT31T/MAT32T/MAT330 in their first year. *Open to 11th graders. Meets during the reserve format.*

MAT31X/32X/40X, a three-term, highly accelerated course, covers a vast breadth of Algebra II and precalculus topics. The pace is demanding, and the problems that students will encounter are challenging. For students who have completed a study of Algebra II and precalculus mathematics, some topics will be familiar, though likely presented in novel contexts; other ideas and techniques will be new. Open to 9th and 10th graders only, through strong performance on placement tests and approval of the department. *Meets during the reserve format.*

MAT31X/40X/41X, a three-term, highly accelerated course, covers a vast breadth of precalculus topics and ends with an introduction to differential calculus. The pace is demanding and the problems that students will encounter are challenging. For students who have completed a study of precalculus mathematics, some topics will be familiar, though likely presented in novel contexts; other ideas

and techniques will be new. Open to 9th and 10th graders only, through strong performance on placement tests and approval of the department. *Meets during the reserve format.*

MAT34T/41T provides a two-term transition as a bridge between our 300- and 400-level calculus courses. Students who start in MAT34T often move through MAT34T/MAT41T/MAT420 in their first year. *Open to 11th graders. Meets during the reserve format.*

■ Transition 4 Mathematics

MATTR4 is two-term course for students who have finished four years of high school mathematics. The goal of this sequence is to review and reinforce the precalculus mathematics students have previously seen, while introducing new concepts and techniques central to our problem-solving curriculum. This course is designed to prepare students for the study of calculus in college. *Meets during the reserve format in fall and winter terms.*

MAT11T/120/130: ALGEBRA

These courses develop facility in working with numbers, tables, equations, inequalities and graphs. The focus is on solving word problems and reading carefully, and thus the building of algebra skills stems from the need to solve problems in a context, rather than from drill and practice for its own sake. Students learn how to use the graphing calculator appropriately as an effective problem-solving tool. In addition, students may do a number of hands-on labs that require them to collect data, make conjectures and draw conclusions. Topics covered include equations and graphs that are linear and quadratic, distinguishing linear data from nonlinear data, inequalities, the basic rules of exponents, and other traditional Algebra I topics. *Meets during the reserve format.*

MAT210/220/230: INTEGRATED MATHEMATICS

The 200-level courses are geometry courses tied to algebraic processes. Students investigate lines, polygons and vectors, in both two and three dimensions. Right-triangle trigonometry is introduced, as are circles and parabolas, the latter viewed from a focus directrix definition. Linear motion is explored, leading to the use of parameters to describe that motion and to an ongoing investigation of optimal paths of travel, an exploration motivating the frequent use of graphing calculators. A dynamic vision of geometry is further encouraged by viewing similarity and congruence through transformations. A study of the concurrence of special lines in a triangle allows for linear data analysis by the use of median-median lines. *Meets during the reserve format.*

MAT310/320/330/400: ADVANCED INTEGRATED MATHEMATICS

The purpose of the 300-level courses is to enable students to expand their view of algebra and geometry to include nonlinear motion and nonlinear functions. The investigation encompasses circular motion and the functions that describe it, ellipses and hyperbolas, exponential and logarithmic functions, dot products

and matrices, and geometry on the surface of the Earth. In particular, logarithms are used to straighten nonlinear data; and matrices are used to describe geometric transformations and various patterns of growth. In preparation for 400-level mathematics, two strands are introduced: first, combinatorics and recursion, leading to the binomial theorem; second, approximation behavior, especially instantaneous rates of change and slopes of nonlinear graphs. *MAT310 meets during the reserve format. MAT 320/330/400 meet during half of the reserve formats.*

MAT311/321/401: ADVANCED INTEGRATED MATHEMATICS — ENRICHED

These courses cover the material of MAT310/320/330/400 in greater depth and at an accelerated pace. *Prerequisite: permission of the department. MAT311 meets during the reserve format.*

MAT410: INTRODUCTION TO CALCULUS

Amid a rich interplay of precalculus concepts, the study of calculus officially begins. Topics include complex numbers, polar coordinates, probability, recursion, functional notation, slope, velocity, asymptotes, the fundamental constant e , the Euler identity and applications of the preceding. *Prerequisite: MAT400 or its equivalent. Meets during half of the reserve formats.*

MAT411: INTRODUCTION TO CALCULUS — ENRICHED

This course covers the material of MAT410 in greater depth and also does some additional problems. *Prerequisite: permission of the department.*

MAT420/430/510/520: CALCULUS

This four-term sequence presents a comprehensive and inductive approach to calculus. Working within contexts whenever possible, key concepts are developed with applications in mind. Students learn to read the language of differential equations, and to appreciate that the two principal divisions of calculus — differential (rate problems) and integral (accumulation problems) — are unified by the Fundamental Theorem of Calculus. Students who are enrolled in 430 or higher in the spring will be prepared to take the AB Advanced Placement examination. Students who are enrolled in 520 will be prepared for the BC examination. In preparation for the examination, MAT430 and MAT520 classes during the spring term may meet during all reserve formats before the examination and fewer times per week after. *Prerequisite: MAT410 or permission of the department. MAT510 and 520 will be offered when numbers permit. Meets during half of the reserve formats.*

MAT421/431/511/521: CALCULUS — ENRICHED

This four-term sequence covers all the material of the 420/430/510/520 courses, with additional applications and explorations, and in greater depth. Working within contexts whenever possible, key concepts are developed with applications in mind. Students learn to read the language of differential equations, and to appreciate that the two principal divisions of calculus —

differential (rate problems) and integral (accumulation problems) — are unified by the Fundamental Theorem of Calculus. Students enrolled in 431 or higher in the spring will be prepared for the AB Advanced Placement examination; students in 521 will be prepared for the BC examination. In preparation for these examinations, MAT431 and MAT521 classes in the spring term may meet during the reserve formats prior to the examination and fewer times per week after. *Prerequisite: permission of the department.*

MAT41C/42C/43C: CALCULUS — A LAB APPROACH

This three-term sequence of courses covers topics from differential and integral calculus. The problem-centered curriculum is built around weekly labs that emphasize graphical and numerical investigations. The focus of these investigations is to develop understanding of essential calculus concepts and their symbolic representations. Throughout the problem sets and labs, students are also expected to explore and write about the calculus ideas they encounter. *Prerequisite: MAT330 or permission of the department. Students who complete MAT41C/42C/43C may not elect MAT400 through MAT521. Students who complete MAT420 or MAT421 may not enter into this sequence. The prerequisite for MAT42C is MAT41C; the prerequisite for MAT43C is MAT42C. Offered: MAT41C: fall and winter terms; MAT42C: winter and spring terms; MAT43C: spring term. Meets during the reserve format.*

MAT40D: TOPICS IN DISCRETE MATHEMATICS

The topics for this course depend on the interests of the instructor, and are usually drawn from everyday experience. They have included fair-division problems, such as apportioning the House of Representatives; network problems, such as map-coloring, scheduling, minimal-cost spanning trees, and the traveling salesman; various methods for extracting group preferences from election data; and quantifying the effect that coalitions have on voting power. *Prerequisite: MAT330 or its equivalent. Offered: fall and winter terms.*

MAT40H: HISTORY OF MATHEMATICS

This is a one-trimester course focusing on the historical development of mathematical ideas, the role of individual character and culture in the advancement of mathematics, and the historical context of major discoveries and changes of viewpoint. Major themes of the course include: the development of mathematics in non-Western cultures, the development of geometry and number theory, the Platonic/Pythagorean synthesis and the study of harmony, the algebraic synthesis of geometry and the early development of algebra, the arithmetization of analysis, and the development of the number concept from ancient to modern times. Both mathematics and writing will be utilized in this course and each student will choose a topic for an expository paper. *Prerequisite: MAT330 or its equivalent. Offered: spring term.*

MAT40J: MATHEMATICS OF SOCIAL JUSTICE

This one-term course will empower students to think critically and objectively about how mathematics can help us better understand complex social issues. When skillfully employed, mathematics has the potential to help uncover inequities. Students will apply techniques from a variety of areas of mathematics, including logic, mathematical modeling, probability, statistics, game theory, simulation and graph theory. Students will investigate contemporary issues in contexts such as gerrymandering, racial profiling, gender bias, drug testing, affordable housing, college admissions and wealth disparities. *Prerequisite: MAT330 or permission of the department. Offered: spring term.*

MAT40L: INTRODUCTION TO SYMBOLIC LOGIC

The study of logic is at the crossroads of mathematics and philosophy, in which we identify principles underlying the ability to reason. Furthermore, logic aids us in determining the ideal ways in which reasoning should occur. Symbolic logic is the branch of logic that helps us reason through the use of a formal language consisting of abstract symbols. Using symbolic notation provides us with a precise and efficient method to reason through a set of premises in order to reach a conclusion. This one-term course will provide students with a strong foundation and working proficiency with logical argument and reasoning. Students will learn how to form deductively valid propositions, arguments and conclusions, as well as how to translate English sentences into symbolic notation and correctly interpret the meaning of the symbolic notation. Topics will include truth tables, truth trees, rules of inference, conditional proof, propositional logic and predicate logic, among others. *Prerequisite: MAT330 or its equivalent. Offered: spring term.*

MAT40S: INTRODUCTION TO STATISTICS

This one-term course provides an overview of the questions addressed by statisticians. Students will discuss where data comes from, such as polls, surveys and experiments; they will study how to organize data and infer relationships between variables. Students will study enough probability to be able to discuss the role of chance and randomness in outcomes. In addition, they will decide how closely the results of polls actually mirror reality and how far the results of experiments can be extrapolated to the wider world. There will be many activities in class, and students will use the computer and calculator to display and analyze the data. *Prerequisite: MAT330 or permission of the department. Students who complete MAT40S may not elect MAT41S/42S/43S. Preference will be given to 12th graders. Offered: fall, winter and spring terms.*

MAT41S/42S/43S: STATISTICS

This sequence of courses is offered fall (MAT41S), winter (MAT42S) and spring (MAT43S).

MAT41S covers the basic principles of descriptive statistics. One-variable topics include graphical representations of data, measures of central tendency and measures of variability. Two-variable data analysis is based on linear regression. Other topics

include probability distributions, sampling techniques, binomial distributions and experimental design. We emphasize the application of statistical techniques to real-world situations. Both the computer and the calculator are integral to the course. During the spring, the course also looks at the principles of hypothesis testing, including non-parametric methods used in the social sciences. *Prerequisite: MAT330 or its equivalent. Students who complete MAT40S may not elect MAT41S/42S/43S.*

MAT42S extends MAT41S by covering topics in inferential statistics, including confidence intervals, tests of significance and statistics in decision-making. We draw problems from the biological and physical sciences, political science, and sociology. *Prerequisite: MAT41S.*

MAT43S builds on the principles of MAT41S and 42S, including more in-depth studies of probability theory. Student-designed projects, based on the statistical procedures learned in the previous courses, constitute important components of the course. This course completes students' preparation for the Advanced Placement exam in Statistics. In preparation for this examination, classes will meet during the reserve format before the test and fewer times per week after. *Prerequisite: MAT42S.*

MAT610/620: MULTIVARIABLE CALCULUS

This two-term sequence re-examines the differentiation and integration processes, and investigates topics such as partial derivatives, level curves and gradients, moving frame description for space curves, the analysis of critical points, double and triple integrals, line integrals, vector analysis, the classical quadric surfaces, Lagrange multipliers, cylindrical and spherical coordinates, and Jacobian matrices. *Prerequisite: MAT520/521 or permission of the department. MAT610 offered: fall and winter terms. MAT620 offered: winter and spring terms.*

MAT640: LINEAR ALGEBRA

MAT640 is an introduction to the theory of linear algebra, the study of systems of linear equations and their solutions. The interplay between algebra and geometry affords powerful and quite different insights into the subject. Topics include: Gaussian elimination, matrices and geometric transformations, eigenvectors and eigenvalues, diagonalization, and discrete dynamical systems. Although there are some applications, this course is quite abstract. *Prerequisite: MAT520/521 or permission of the department. Offered: spring term.*

■ Selected Topics in Advanced Mathematics

For advanced students, the Mathematics Department offers special courses that feature topics typically taught in college. Since this material can be presented with varying levels of formality, we have created two different settings for such courses, MAT690 and MAT790, with MAT700 as a prerequisite for MAT790. The specific topics for MAT690 and MAT790 vary from year to year and are

dependent upon the interests and backgrounds of the students involved. Past topics for such courses have included abstract algebra, real analysis, complex analysis, topology, combinatorics, geometry of polyhedra and surfaces, number theory, differential equations, mathematical physics, financial mathematics, advanced Euclidean and non-Euclidean geometry, dynamical systems and game theory. *Offered: Terms vary year to year, based on information gathered from eligible students during the prior year.*

MAT690: SELECTED TOPICS IN MATHEMATICS

The topics in MAT690 will be studied with an emphasis on intuition and computational facility. At the same time, one should note that commitment to pursue difficult mathematical ideas is a necessary quality for doing well. While some theorems and their proofs will be examined, the level of abstraction will be appropriate to an introductory course in advanced material. *Prerequisite: MAT520/521 or permission of the department.*

MAT700: FOUNDATIONS OF ABSTRACT MATHEMATICS

This course constitutes a bridge between calculus and theoretical, proof-based courses such as real analysis, abstract algebra and set theory. The emphasis is on understanding and mastering increased levels of rigor, dealing with mathematical notation, and learning how to write, present and analyze proofs. Course content includes axiomatic systems, the principle of mathematical induction, proof by contradiction, existence principles, mathematical logic, elementary set theory, countable and uncountable sets, bijections between sets, combinatorics, and abstract structures and isomorphism. *Prerequisite: MAT520/521 or permission of the department.*

MAT790: SELECTED TOPICS IN MATHEMATICS

The topics in MAT790 will be presented and developed with the full formality of modern mathematics. The mathematics presented will be characterized by rigor and depth and developed in an abstract manner. The student is expected to be able to read an advanced mathematics text and follow a presentation oriented around theorems and their proofs. Students may be expected to do some creative work in deriving mathematical results and presenting them in a rigorous fashion. *Prerequisite: MAT700 or permission of the department.*

Modern Languages and Cultures

Modern language classes at Exeter promote authentic engagement through immersion and participation. Instructors rely on a variety of technologies and media — books, online resources, games, films, videos, music, television programs, newspapers and magazines — to support experiential language acquisition. Contact with the language through multiple media will allow students to deepen their linguistic and cultural competency at all levels.

Students should choose the language that interests them most. In the Modern Languages and Cultures Department, students can meet the language diploma requirement through Chinese, French, German, Japanese, Russian or Spanish. The accelerated two-term sequence in Italian and three-term sequence in Arabic are for seniors only, and do not meet the diploma requirement. If students wish to study a language that they began at a previous school, they may take a placement test. Students placed into fourth-year or higher-level courses (400-level or above) can meet the diploma requirement by successfully completing a course at that level. Many students choose to begin a new language either upon arrival at the Academy or after completing the diploma requirement in one of the six specified languages.

In keeping with the Academy's mission and core values, the department seeks to nurture responsible global citizenship. Students will develop skills of communication and collaboration through multiple avenues, including literature, history, art, philosophy, sports, films and current events. A wide selection of advanced courses will provide students with a unique opportunity to pursue their passions and achieve a high degree of competency in their chosen language. Exeter's options for term-abroad programs allow seniors to apply their classroom learning to real-world experiences, live with host families, hone their language skills via day-to-day immersion, and actively engage in the richness of intercultural literacy.

While studying modern language at Exeter, students will grow to understand and celebrate different cultural traditions. The department values the diversity that students bring to the Harkness table, and students are encouraged to share their own stories through the examination of distinctly different ways of speaking, thinking and understanding the world. An exploration of alternative perspectives will help students recognize their own cultural filters and assumptions. Harkness discussion in a new language fosters flexibility, adaptability, discernment of nuance, and comfort with the ambiguities of languages and

cultures in constant evolution. Whether working in small groups or around the table, students will acquire new ways of thinking and being in the world while developing intercultural skills for lifelong learning.

Note: All modern language courses through Language 231, with the exception of the accelerated Italian course, meet during the reserve format. Studies in Francophone Cinema and Hispanic Cinema also meet during the reserve format.

■ Arabic

ARA111/121/131: ACCELERATED ARABIC FOR SENIORS

This sequence of courses is offered fall (ARA111), winter (ARA121) and spring (ARA131). This intensive three-term sequence introduces students to the phonology script and syntax of Modern Standard Arabic. Students will concentrate on developing the four skills of reading, speaking, listening and writing. Texts will be supplemented with cultural materials representative of the contemporary Arabic world and will include newspapers, magazines and videos. *Open to 12th graders only. Students will be selected on the basis of proven linguistic abilities. Prerequisite: permission of the department.*

■ Chinese

CHI110/120/130: ELEMENTARY CHINESE

This sequence of courses is offered fall (CHI110), winter (CHI120) and spring (CHI130). These courses are designed to provide students with a new cultural lens through which to see both the Chinese world as well as themselves. In addition to traditional language-learning exercises, students achieve language and cultural proficiencies through games, role-play, songs, calligraphy and other interactive exercises. They also gain a new perspective on the concepts of respect and courtesy, both of which are deeply rooted in Chinese culture. They are able to greet people, talk about family, friends, home and school life, describe their hobbies and daily routines, and converse in shopping situations. Through the celebrations of traditional Chinese festivals such as the Mid-Autumn Festival and Chinese New Year, students can interact with the Chinese world via cooking and tasting authentic Chinese food, making arts and crafts, and watching snippets of linguistically relevant Chinese television programs. This intensive introduction to the language of China is a fascinating jump-start through the doorway to the Middle Kingdom and the language, culture and perspectives that have shaped its people.

CHI111/221/231: ACCELERATED CHINESE

This sequence of courses is offered fall (CHI111), winter (CHI221) and spring (CHI231). This three-term sequence presents the material of the first two years of the Mandarin Chinese program and promotes to CHI310 in the fall. This course is designed for students with previous oral and written experience in Chinese. *Prerequisite: placement test and permission of the department.*

CHI210/220/230: INTERMEDIATE CHINESE

This sequence of courses is offered fall (CHI210), winter (CHI220) and spring (CHI230). Building heavily upon previously learned vocabulary and grammar structures, students broaden their assimilation of Chinese cultural and social practices. Students learn to apply linguistic structures and cultural norms in various real-life situations that include dining out, visiting the doctor, renting an apartment, making travel plans and attending social gatherings. Through various cultural comparisons, students learn to express their own identities while enriching their developing view of China and its culture. Through readings, writings and frequent oral exercises, students temper their social skills and continue to embolden their developing linguistic faculty with Mandarin Chinese.

CHI310/320/400: ADVANCED CHINESE

This sequence of courses is offered fall (CHI310), winter (CHI320) and spring (CHI400). Students step beyond the basic phase of language acquisition and come to realize their autonomy in self-expression. While the tools of language become more involved, the courses provide the student with more space to explore deeper sociocultural issues, such as the importance of education, the social role of the internet and issues pertaining to adult life (i.e., matters of part-time work and relationships). Role-play activities, Harkness discussions and individual oral presentations allow students to compare their own experiences with those of their contemporaries in the Chinese-speaking world. The courses are designed to develop another layer of understanding regarding relevant social issues and more time for individual expression at the table.

CHI311/321/411: ADVANCED CHINESE (ACCELERATED)

This sequence of courses is offered fall (CHI311), winter (CHI321) and spring (CHI411). It helps students who already possess a strong oral proficiency use more sophisticated vocabulary and sentence structures to engage in readings, writing, oral presentations and discussions on various cultural and social topics. Focal points of the course include traditional Chinese holidays, Chinese health and lifestyle, gender equality, environmental issues and other recent social changes in China. Students gain insight into social position and hierarchical standards within Chinese society and their relationship to the inner workings of Chinese society. A variety of authentic materials such as video/music clips, television programs and stories are used to deepen students' linguistic competency and cultural understanding. *Prerequisite: CHI231, placement test and permission of the department.*

CHI502/503/504: CONTEMPORARY CHINESE LANGUAGE AND LITERATURE

This sequence of courses is offered fall (CHI502), winter (CHI503) and spring (CHI504). These courses are designed for the advanced student who possesses sufficient oral and writing skills to analyze and discuss literary and nonliterary texts. This sequence explores a variety of topics, including the generation gap, social media, environmental issues, and the central dichotomy between the modern and the traditional of China. Regular oral and writing practices provide students with a means to express themselves in discussion/debate with a higher degree of linguistic and cultural proficiency. Resources include articles, video/music clips and short stories. Beyond attaining linguistic enhancement, students reflect on their own identities and gain new cultural perspective. This sequence prepares students for the Advanced Placement exam in Chinese. *Prerequisite: CHI400 or permission of the department.*

CHI521/531/541: CONTEMPORARY CHINESE LANGUAGE AND LITERATURE (ACCELERATED)

This sequence of courses is offered fall (CHI521), winter (CHI531) and spring (CHI541). These courses are designed for the advanced students with high oral and writing proficiency to analyze and discuss literary and nonliterary texts. Through various media clips, newspaper articles and short stories, students read, discuss and debate current social and economic issues in China. Topics may include, for example, population, the housing market, education, employment, feminism, concepts of dating and marriage, e-commerce and economic development. Beyond attaining linguistic enhancement, students reflect on their own identities and gain new cultural perspective. This sequence prepares students for the Advanced Placement exam in Chinese. *Prerequisite: CHI411 or permission of the department.*

CHI555: SOCIOLINGUISTIC EXPLORATION THROUGH TV SERIES IN CHINESE

This course offers an engaging approach to understanding sociolinguistics through the lens of contemporary Chinese TV series. By analyzing language use, social dynamics and cultural contexts in popular Chinese television shows, students will gain insight into how language reflects and shapes social identity, gender, class, region and power relations in Chinese-speaking societies. In studying episodes from selected popular Chinese dramas, students will not only experience a more immersive approach to language absorption but also deepen their understanding of sociocultural issues within contemporary China. Students will discuss, analyze and present on a variety of topics, including dating and personal relationships, education, family values and workplace culture. *Prerequisite: any 500-level Chinese course. Offered: fall term.*

CHI560: CONTEMPORARY CHINESE CINEMA

This seminar course focuses on contemporary Chinese language films. Course curriculum includes film viewing, reading of film scripts and critiques, analytical discussion, and writing on related topics such as characterization, plot, themes and societal

background. Potential films include *Eat Drink Man Woman* (1994), *To Live* (1994), *Shower* (1999) and *Dying to Survive* (2018). Students learn about the historical background covering the 1940s to the 1980s (Civil War, the Land Reform Movement, the Great Leap Forward, the Cultural Revolution, Economic Reform and Opening Up Policy, etc.). Furthermore, they gain a fuller understanding of weighty sociocultural topics such as the value of filial connections, family structure, the traditional and the modern, and the conflict between social conformity and individual desire. *Prerequisite: any 500-level Chinese course. Offered: winter term.*

CHI580: CHINESE THROUGH DIGITAL MEDIA

This advanced course aims to hone students' conversational skills by exploring a variety of media throughout the Chinese-speaking world. Students will watch, research and discuss topics through contemporary documentaries, television shows and programs, podcasts, video talks, music and short films. Themes may include Chinese culinary culture, intricacies in family structure and values, the hub of human relationships, Chinese education and Chinese immigration communities. Activities may include Chinese cooking, in-class debate and student-directed plays. *Prerequisite: any 500-level Chinese course. Offered: spring term.*

CHI590: SELECTED TOPICS IN CHINESE

For advanced students of the language, this course features topics typically taught in college. The topics for this course vary from year to year and are dependent upon the interests and backgrounds of the students involved.

■ French

FRE110/120/130: ELEMENTARY FRENCH

This sequence of courses is offered fall (FRE110), winter (FRE120) and spring (FRE130). Students learn to communicate information about their own identities while developing sensitivity to intercultural practices in the Francophone world. They are able to greet people, describe appearances and personalities, and talk about family, friends and community. Students learn to express what they like to do, describe their hobbies and leisure activities, and converse about daily routines and life at school. They practice essential conversation necessary for travel — making reservations, asking and giving directions, ordering in restaurants and shopping in markets. By the end of the first-year sequence, students are capable of storytelling in the past, present and future, and they can apply the linguistic and cultural norms necessary for effective introductory communication. To supplement the acquisition of receptive and interpretive skills, students read level-appropriate texts in authentic language.

FRE12T: TRANSITION FRENCH 1

For students who have had one or two years of French in middle school and/or one year in high school, this course reviews basic conversational skills, cultural norms and linguistic patterns. The two-term sequence accelerates students through the first-year

program and can promote to either FRE120 or FRE13T in the winter term. To supplement the acquisition of receptive and interpretive skills, students read level-appropriate texts in authentic language. *Offered: fall term.*

FRE13T: TRANSITION FRENCH 2

This course completes the practice of introductory conversational and linguistic skills. Students acquire depth and breadth for intercultural conversations through authentic level-appropriate readings. The course may promote to FRE130 or FRE210 in the spring term. *Offered: winter term.*

FRE210/220/230: INTERMEDIATE FRENCH

This sequence of courses is offered fall and spring (FRE210), fall and winter (FRE220), and winter and spring (FRE230). Students continue their study of spoken and written French with an in-depth review of important cultural concepts and linguistic structures. Throughout this sequence, students will learn to explore connections such as the relationship between identity and geography, current events and the media, problems and solutions [in society, composition and roles in families, science and technology, work and play, and man and nature. Level-appropriate readings reinforce these themes and provide additional structures necessary to support meaningful conversation.

FRE310/320: ADVANCED FRENCH

This sequence of courses provides students with the tools they need to improve the quality of their written and oral production. The courses allow students to expand their linguistic and cultural knowledge through selected Francophone readings, combined with short films and authentic comic book excerpts. The level-appropriate readings support an increased focus on collaborative and interpersonal skills, and encourage students to explore diverse voices and perspectives. *Offered: fall and spring terms (FRE310), and fall and winter terms (FRE320).*

FRE400: THE COLLISION OF WORLDS IN COLONIAL AND POSTCOLONIAL FRANCOPHONE LITERATURE

This course explores conflicting attitudes about history, politics, culture and identity explicit and implicit in colonial and postcolonial Francophone literary production. Topics may include *négritude*, *oralité*, *engagement*, *moeurs*, *désillusion*, *religion* and *justice sociale*. The course may focus on specific geographical areas, genres and/or authors. Students have the opportunity to enrich their cultural competence through the study of current events, documentaries, films and television. *Prerequisite: FRE320. Offered: winter and spring terms.*

Note: The following 500-level courses (except FRE590) may be taken in any order after completion of FRE400. It is recommended that students discuss 500-level course selections with their current instructor.

The sequence FRE502/503/504 will focus on the themes

suggested by the AP French course framework and can be taken in any order after completing FRE400 or any 500-level course.

While FRE502/503/504 emphasizes in particular the topics of the AP French Language and Culture exam, the French curriculum in its entirety prepares students to control and synthesize audio/visual sources and produce spoken and written interpersonal and presentational modes of communication as defined by the current AP course framework.

FRE502: INDIVIDUALITY, COMMUNITY, SOCIETY: ASPECTS OF IDENTITY

This course explores the quest of one's identity through facets of Francophone societies. How can culture, customs, family, gender and language shape and influence identity in a progressively multicultural society? Materials may include essays, short stories, novels, radio programs, films, podcasts, newspapers and magazine articles. This course provides a special review for the AP French Language and Culture exam. *Offered: fall term.*

FRE503: FRANCE AND THE FRANCOPHONE WORLD IN THE 21ST CENTURY

This course explores contemporary social issues and global challenges, technological and environmental, in the French-speaking world. Materials may include essays, short stories, novels, radio programs, films, podcasts, newspapers and magazine articles. This course provides a special review for the AP French Language and Culture exam. *Offered: winter term.*

FRE504: ART, MUSIC AND LITERATURE

This course explores the role of artistic creation and the concept of beauty from the traditional to the modern, the role of art to challenge or praise the status quo. Materials may include essays, short stories, novels, radio programs, films, podcasts, newspapers and magazine articles. This course provides a special review for the AP French Language and Culture exam. *Offered: spring term.*

FRE550: FRANCOPHONE THEATER

This course examines a variety of plays, focusing on character interaction against the backdrop of historical, social and geographical diversity. *Note: This course will be offered every other year. Offered: fall term.*

FRE552: FROM FOLLY TO REASON

Giants, misers, hypochondriacs, lovesick poets, eternal optimists — these are but a few of the characters that abound in this literature course that begins with Rabelais' *Gargantua* and ends with Voltaire's *Candide*. *Note: This course will be offered every other year. Offered: winter term.*

FRE553: GREAT NOVELS

This course is an in-depth study of one or two Francophone masterpieces and gives special attention to the historical, cultural and social context in which the work was written. Possible choices include Roch Carrier's *La Guerre, Yes Sir!*, Gustave Flaubert's *Madame Bovary*, Cheik Hamidou Kane's *L'aventure ambiguë*, Guy de Maupassant's *Pierre et Jean*, Ferdinand Oyono's *Une vie de boy* and Stendahl's *Le Rouge et le Noir*. *Note: This course will be offered every other year. Offered: spring term.*

FRE554: HUMANISM

This course studies selected works by great Francophone writers of the past and present, whose reaffirmation and defense of human dignity, or questioning of it, give them lasting significance. Readings might include works by François Rabelais, Michel de Montaigne, Molière, Voltaire, Jean-Paul Sartre and Albert Camus. *Note: This course will be offered every other year. Not offered 2026-27.*

FRE555: CHANGE MAKERS

Tracing the struggle for human rights through current events, literature and film, this course focuses on the crises, upheavals, and moral miscarriages of justice in various countries of the Francophone world. *Note: This course will be offered every other year. Not offered 2026-27.*

FRE556: STUDIES IN FRANCOPHONE CINEMA

The readings, discussions and writing in this course will center on a series of French films chosen for their cultural, historical and artistic value. Students will read scenarios, source material or summaries of the films, and will discuss and write about characterization, plot, themes, and geographical and cultural aspects. *This course meets during the reserve format to allow for film viewing. Note: This course will be offered every other year. Not offered 2026-27.*

FRE590: SELECTED TOPICS IN FRENCH

This course is offered at student or departmental initiative and may change from year to year. In 2026-27 the following course will be offered:

FRE590: SOCIO-LINGUISTIC EXPLORATION THROUGH TV SERIES IN FRENCH

This course examines modern Francophone society through an exploration of French-language series from a wide range of Francophone countries. Students will view, discuss, analyze and present on different aspects, including but not limited to identity, community, art and history. The course might also include study of the written material that inspired these series. Exposure to authentic audio will allow students to develop a better understanding of spoken French and provide a wider range of authentic vocabulary as it is used in everyday situations. In place of a text, students must subscribe to a video platform for the duration of the term. *Prerequisite: any 500-level French course. Offered: spring term.*

■ German

GER110/120/130: ELEMENTARY GERMAN

This sequence of courses is offered fall (GER110), winter (GER120) and spring (GER130). Students learn to communicate information about their own identities while developing sensitivity to intercultural practices in German-speaking countries: Austria, Germany and Switzerland. They are able to greet people, describe appearances and personalities, and talk about family, friends and community. Students learn to express what they like to do, describe their hobbies and leisure activities, and converse about daily routines and life at school. They practice essential conversation necessary for travel — making reservations, asking and giving directions, ordering in restaurants and shopping in markets. By the end of the first-year sequence, students are capable of storytelling in the past, present and future, and they can apply linguistic structures and cultural norms for effective introductory communication. To supplement the acquisition of receptive and interpretive skills, students read level-appropriate texts in authentic language.

GER111/221/231: GERMAN TWO YEARS IN ONE

This sequence of courses is offered fall (GER111), winter (GER221) and spring (GER231). This three-term sequence presents the material of the first two years of the German program. It is recommended for students who are already familiar with grammatical systems or who have had some exposure to German. The course includes the reading program of the elementary and intermediate courses. This sequence promotes to GER310 in the fall.

GER210/220/230: INTERMEDIATE GERMAN

This sequence of courses is offered fall (GER210), winter (GER220) and spring (GER230). Language proficiency, reading, writing, vocabulary building and continued investigation of German-speaking societies are among aims of this sequence. Grammatical, speaking and writing exercises are coordinated with a reading program that includes literary and nonliterary texts from a variety of media — short novels, stories, news articles, music, video, etc. GER230 includes an examination of the German presence in the United States, and considers the contributions of German-Americans and German-American communities.

GER310/320: ADVANCED GERMAN

This sequence of courses is offered fall (GER310) and winter (GER320). The sequence provides a systematic grammar review and continued work on speaking, reading and writing skills. Literary texts from German-speaking countries and material from other media provide the basis for discussion of social, cultural and ethical issues.

GER400: LITERATURE OF EXILE, FLIGHT AND MIGRATION

The readings in this course focus on writings by members of under-represented communities in German-speaking countries, and our

discussions center on themes of home, belonging, exile and refuge. There is continued development of speaking, listening and writing skills. *Offered: spring term.*

GER502: GERMAN BESTSELLERS

The 502/503/504 courses focus on recognized masterpieces of German writing, with both classical and contemporary authors represented. Social, ethical and artistic issues are explored in each course. The readings in GER502 will include contemporary bestsellers that shed light on German history, culture, thought and values. *Prerequisite: GER400. Offered: fall term.*

GER503: POST-HOLOCAUST WRITING

The 502/503/504 courses focus on recognized masterpieces of German writing, with both classical and contemporary authors represented. Social, ethical and artistic issues are explored in each course. GER503 explores Germany and Austria's coming to grips with the Nazi past and the horrors committed during that era. Readings may include works by Katja Petrowskaja, Jenny Erpenbeck and Paul Celan. *Prerequisite: GER400. Offered: winter term.*

GER504: CURRENT ISSUES IN GERMAN-SPEAKING COUNTRIES

The 502/503/504 courses focus on recognized masterpieces of German writing, with both classical and contemporary authors represented. Social, ethical and artistic issues are explored in each course. GER504 examines issues presently dominating the media, literature, theater and cinema in Germany, Austria and Switzerland. Among the themes explored are immigration and integration, the fate of the European Union, the rise of the Green and far-right parties, urbanization, the terrorist threat, etc. Each course includes advanced conversation and composition components. *Prerequisite: GER400. Offered: spring term.*

GER590: SELECTED TOPICS IN GERMAN

For advanced students of the language, this course features topics typically taught in college. The focus might be on one literary masterpiece, readings from German-language Nobel-prize winners, cinema, or other areas depending on the interests and backgrounds of the students involved.

■ Italian

ITA121/131: ACCELERATED ITALIAN FOR SENIORS

This sequence of two accelerated courses in Italian covers all the basic skills, with emphasis on a reading program leading to the study of a work of contemporary Italian literature. The course is for seniors with strong preparation in a first foreign language. *Prerequisite: open to 12th graders with a strong preparation in a first foreign language, or 11th graders by departmental permission. Offered: winter and spring terms.*

■ Japanese

JPN110/120/130: ELEMENTARY JAPANESE

This sequence of courses is offered fall (JPN110), winter (JPN120) and spring (JPN130). These courses introduce students to the language of everyday life and culture. Students practice the basic skills: speaking, listening, writing, reading and cultural competency. Students learn how showing respect to others is engrained in the Japanese language. Conversational skills and linguistic structures are acquired through fun and nurturing interactive games and activities. With the aid of computer applications, students learn *hiragana*, *katakana* and *kanjis*. Students enhance intercultural skills through short stories, movies, songs, comic books, anime and television shows. Activities include Japanese meals, snacks, calligraphy, origami and field trips to Boston such as a visit to the Museum of Fine Arts, the Japan Festival or the New Year Celebration at the Boston Children’s Museum. Students will correspond with Japanese students in Tokyo through video mail. Resources include an eBook textbook with embedded videos, audio, dictionary, study cards and more; iPad applications include texts, video, audio, computer-based applications and internet materials.

JPN121/131: ACCELERATED ELEMENTARY JAPANESE

This sequence of two accelerated terms (JPN121/131) covers the material of the first three terms of elementary Japanese (JPN110/120/130). These two courses prepare students for JPN210. Students who have satisfied their language requirement in a first foreign language and wish to begin a second language in the winter term may be particularly interested in enrolling in this class, assuming sufficient enrollment. *Offered: winter and spring terms in years when Japanese 110 is not offered due to low enrollment.*

JPN210/220/230: INTERMEDIATE JAPANESE

This sequence of courses is offered fall (JPN210), winter (JPN220) and spring (JPN230) and covers daily conversational skills, cultural norms and linguistic patterns. Students learn about various aspects of Japanese culture through reading authentic books. The sense of “*on*” (the debt of gratitude), feminism, family structure and food are introduced. Topics include the origin of “lucky cats,” how to make sushi, Urashima Taro, etc. Students have the opportunity to participate in activities such as making sushi and corresponding with Japanese students in Tokyo through the internet and letters.

JPN310/320/400: ADVANCED JAPANESE

This sequence of courses is offered fall (JPN310), winter (JPN320) and spring (JPN400). Students acquire depth and breadth for intercultural conversations. Various cultural and social topics — environmental issues and gender issues, compassion for others, the beauty of hard work, power structure, issues with vanity and self-image — are provided to deepen students’ knowledge of Japan and its people through authentic material such as short stories, internet materials, video clips, movies and comic books.

JPN502/503/504: ADVANCED READINGS IN JAPANESE

This sequence of courses is offered fall (JPN502), winter (JPN503) and spring (JPN504). The focus of the sequence is to increase skills in reading, analysis and discussion, and prepare students for living and working in Japanese culture. Students will be familiar with cultural concepts such as societal duties and obligation, sexism, environmental issues, discrimination in Japan, and the concept of *hara-kiri*, the sense of honor. Resources include a variety of original readings, such as Japanese classical literature and contemporary novels by Haruki Murakami, as well as newspaper articles, movies, internet materials, video clips and comic books. These courses prepare students for the Advanced Placement examination in Japanese Language and Culture. *Prerequisite: JPN400 or permission of the department.*

JPN590: SELECTED TOPICS IN JAPANESE

For advanced students of the language, this course features topics typically taught in college. The topics for this course vary from year to year and are dependent upon the interests and backgrounds of the students involved.

■ Russian

RUS110/120/130: ELEMENTARY RUSSIAN

This sequence of courses is offered fall (RUS110), winter (RUS120) and spring (RUS130). These three courses introduce students to both spoken and written Russian. The four language skills of listening, speaking, reading and writing are developed simultaneously. Students master the fundamentals of Russian grammar through frequent oral and written practice. In this sequence, students converse on everyday topics revolving around different life matters: greetings, personal information, going about the city, school and family, cooking, shopping and travel. Students read selected short stories, fairy tales, poems and blogs, watch shows and cartoons, and write narratives and creative pieces. Students are introduced to the language, society and culture of Russia and of other countries where the language is widely spoken. Resources include texts, video, audio, and computer-based and internet materials.

RUS111/221/231: ACCELERATED RUSSIAN

This sequence of courses is offered fall (RUS111), winter (RUS221) and spring (RUS231). This three-term sequence presents the material of the first two years of the Russian program. It is recommended for students with experience in learning languages or who have had some exposure to Russian. The course includes the reading program of the elementary and intermediate courses. This sequence promotes to RUS310 in the fall.

RUS210/220/230: INTERMEDIATE RUSSIAN

This sequence of courses is offered fall (RUS210), winter (RUS220) and spring (RUS230) and continues the study of oral and written Russian. Topics involve family history, along with descriptions of people’s appearance and personality placed within realistic settings,

situations and contexts. Special attention is given to grammatical accuracy. A comprehensive review of grammar is carried out, and more sophisticated structures are introduced. Students write short essays and personal narratives. Culture is an integral part of the sequence; students gain additional proficiency by reading and discussing selected texts from a variety of sources, such as short stories, poems, fairy tales, essays, articles, blogs and biographies of Russian writers, poets and scientists. This sequence also introduces classical literature, including selected stories by A. Chekhov and M. Zoshenko.

RUS310/320/400: ADVANCED RUSSIAN

This sequence of courses is offered fall (RUS310), winter (RUS320) and spring (RUS400). In this sequence of courses, students consolidate their knowledge and continue to acquire new vocabulary by reading and discussing selected works of Russian classical and contemporary literature, including the works of L. Tolstoy and F. Dostoevsky, historical essays, fairy tales and internet materials. As part of the sequence, students study “Cinema for Russian Conversation.” They state opinions, persuade, and analyze texts and movies both verbally and in writing. Culture continues to be an integral part of the sequence. Students watch, read and discuss news, current events, television shows, performances, social media and more.

RUS502/503/504: ADVANCED READINGS IN RUSSIAN

This sequence of courses is offered fall (RUS502), winter (RUS503) and spring (RUS504). These courses focus primarily on classical Russian literature and poetry. Students read works by Alexander Pushkin, Mikhail Lermontov, Anton Chekhov, Fyodor Dostoevsky and Leo Tolstoy. Writing and discussion are also integral parts of this course, as students relate themes found in the classical texts to experiences and issues in contemporary society and their own lives. The reading is combined with cinematic adaptations of classical literature (*Anna Karenina*) and opera (*The Queen of Spades*). Additional readings and resources come from contemporary Russian literature, newspapers, magazines, television programs, documentaries and other internet materials, as shaped by instructor and student interest. *Prerequisite: RUS400 or permission of the department.*

RUS590: SELECTED TOPICS IN RUSSIAN

For advanced students of the language, this course features topics typically taught in college. The topics for this course vary from year to year and are dependent upon the interests and backgrounds of the students involved.

■ Spanish

SPA110/120/130: ELEMENTARY SPANISH

This sequence of courses is offered fall (SPA110), winter (SPA120) and spring (SPA130). Students begin to learn to express themselves about their own identities while developing sensitivity to intercultural practices in the Spanish-speaking world. They are able to greet people, describe appearances and personalities, and talk about family, friends

and community. Students learn to express what they like to do, including describing their hobbies, cultural festivals, and sports and leisure activities, and converse about daily routines and life at school and at home. They practice essential conversation necessary for travel — making reservations, asking and giving directions, ordering in restaurants and shopping in markets. By the end of the first-year sequence, students are capable of storytelling in the past, present and future, and they can apply the linguistic structures and cultural norms necessary for effective introductory communication. To supplement the acquisition of receptive and interpretive skills, students read level-appropriate texts in authentic language.

SPA12T: TRANSITION SPANISH 1

For students who have had one or two years of Spanish in middle school and/or one year in high school, this course reviews basic conversational skills, cultural norms and linguistic patterns. Topics studied are similar to those covered in SPA110 and the beginning of SPA120. To supplement the acquisition of listening and speaking skills, students read level-appropriate texts in authentic language. After 12T, students typically progress to either SPA120 or SPA13T in the winter term. *Offered: fall term.*

SPA13T: TRANSITION SPANISH 2

This course completes the practice of introductory conversational and linguistic skills. Students acquire depth and breadth for intercultural conversations through authentic, level-appropriate readings and other resources. Topics studied are similar to those covered in SPA120 and the beginning of SPA130 — daily routines, travel throughout Spanish-speaking countries, foods and shopping. After 13T, students typically progress to either SPA130 or SPA210 in the spring term. *Offered: winter term.*

SPA13X/21X: TRANSITION SPANISH 2 — ACCELERATED

This course sequence offers an accelerated first-year review of Spanish in two terms. It completes the practice of introductory conversational and linguistic skills. Students acquire depth and breadth for intercultural conversations through authentic, level-appropriate readings and other resources. Topics studied include daily routines, travel through Spanish-speaking countries, foods and shopping. This sequence promotes to SPA220 in the spring term, based on the level of linguistic competence and recommendation by the instructor. *Offered: fall (SPA13X) and winter (SPA21X) terms.*

SPA12H/13H/21H: TRANSITION SPANISH FOR HERITAGE SPEAKERS

SPA12H/13H/21H is a three-course sequence designed to meet the needs of native or heritage speakers with a certain degree of oral proficiency. These three courses aim to provide an environment where heritage speakers can build on the language base they already have. Students will have the chance to develop and enhance their reading and writing abilities while further improving their oral skills (listening and speaking) by acquiring new vocabulary and being exposed to different contexts and registers. SPA12H will center on indicative tenses and the development of personal narratives; SPA13H

will focus on the use of the subjunctive mood and the exploration of identity in context; and SPA21H will emphasize advanced grammar, close reading and reflective writing. This sequence promotes to SPA220 or higher in the following fall term, based on the level of linguistic competence and recommendation by the instructor. *Offered: fall (SPA12H), winter (SPA13H) and spring (SPA21H) terms.*

SPA210/220/230: INTERMEDIATE SPANISH

This sequence continues the study of spoken and written Spanish begun in the sequence of SPA110/120/130. It completes the study of fundamental forms and structures, and includes a program of readings that span a variety of cultures, regions and time of Latin America, Spain and Spanish-speaking communities of the United States. These three courses introduce students to the history of the Spanish-speaking world and delve into the experience of immigrants and indigenous communities through readings and discussions.

Note: SPA210 is not offered winter term.

SPA310/320: ADVANCED SPANISH

This entry into advanced-level studies in SPA310 and SPA320 allows students to expand their linguistic and cultural knowledge through literary readings combined with other audiovisual, printed and journalistic sources. The level-appropriate readings support an increased focus on collaborative and interpersonal skills and encourage students to explore diverse voices and perspectives from the world's Spanish-speaking nations and communities. In these two courses, students will cover a variety of genres, including short stories, novels, plays, poetry, essays, graphic novels and journalism. At this level, students review many areas of grammar and structure covered in second-year courses, while moving their focus into increasingly complex grammar, structures and vocabulary — necessary elements for understanding, discussing and writing about more challenging subject matter. *Prerequisite: SPA230.*

SPA400: PANORAMA OF LATIN AMERICAN AND SPANISH READINGS

Continuing the study of advanced language topics, culture and history of Spanish-speaking communities on multiple continents, reading material in SPA400 may include short stories by such writers as Isabel Allende, Gabriel García Márquez, Elena Poniatowska and Hernando Téllez, works by Rosa Montero and other journalists, and poetry by Rosario Castellanos, Nicolás Guillén and other authors. SPA400 prepares students for continued study of literature and other elective courses. *Prerequisite: SPA320.*

Note: The following 500-level courses (except SPA570 and SPA590) may be taken in any order after completion of SPA400. It is recommended that students discuss 500-level course selections with their current instructor.

The sequence SPA502/503/504 will focus on the themes suggested by the AP Spanish course framework and can be taken in any order after completing SPA400 or any 500-level course.

While SPA502/503/504 emphasizes in particular the topics of the AP Spanish Language and Culture exam, the Spanish curriculum in its entirety prepares students to control and synthesize audiovisual sources and produce spoken and written interpersonal and presentational modes of communication.

SPA502: 21ST CENTURY CHALLENGES AND OPPORTUNITIES

Students increase their vocabulary, range of expression and understanding of grammatical structures, while exploring topics related to science and technology, environmental issues and other 21st-century challenges, as they pertain to Spanish speaking countries. Materials may include essays, short stories, radio programs, films, newspapers and magazine articles. Attention is given to the development of various forms of written and verbal communication — interpretive, persuasive, interpersonal and presentational — using AP Spanish guidelines and rubrics. This course, along with SPA503 and SPA504, provides a special review for the AP Spanish Language and Culture exam in May but need not be taken in sequence or in conjunction with the AP examination. *Offered: fall term.*

SPA503: FAMILY, COMMUNITY AND CONTEMPORARY LIFE

Students continue to develop all of their linguistic skills while exploring topics related to customs, values and traditions, and contemporary issues in Spanish-speaking cultures. Materials may include novels, essays, short stories, radio programs, films, newspapers and magazine articles. Attention is given to the development of various forms of written and verbal communication: interpretive, persuasive, interpersonal and presentational. This course, along with SPA502 and SPA504, provides a special review for the AP Spanish Language and Culture exam in May but need not be taken in sequence or in conjunction with the AP examination. *Offered: winter term.*

SPA504: THE EMERGING SELF: ART AND IDENTITY

Students expand on their linguistic skills and knowledge of Spanish-speaking cultures and groups through the exploration of the arts, and topics related to the development of individual and group identities. Materials may include novels, essays, short stories, radio programs, films, newspapers and magazine articles. Attention is given to the development of various forms of written and verbal communication: interpretive, persuasive, interpersonal and presentational. This course, along with SPA502 and SPA503, provides a special review for the AP Spanish Language and Culture exam in May but need not be taken in sequence or in conjunction with the AP examination. *Offered: spring term.*

SPA550: CONTEMPORARY HISPANIC THEATER

In this course we offer a creative approach to discovering what theater is through the reading of a wide variety of original plays written by selected relevant authors of all times from Latin America and Spain. In addition to reading, analyzing and discussing the plays

to examine cultural and linguistic elements, students may also act out several monologues and scenes on stage, and examine other aspects of theater arts while practicing their advanced Spanish skills. The course may also include writing, directing and acting in a final student-made production. *Offered: fall term.*

SPA552: FANTASY AND REALITY IN THE LATIN AMERICAN NARRATIVE

This course explores literary works where fantasy or mythical elements merge with reality, introducing us to an unexpected world. We study pioneering works of fiction that delve into the evolution of the prose narrative in Spanish, culminating in the Latin American boom of the 20th century, considered a zenith in world literature, followed by the flourishing of magical realism in the literature of the American hemisphere. Representative works are chosen from authors such as Quiroga, Uslar Pietri, Borges, Fuentes, Cortázar, Esquivel, Allende, García Márquez and Rulfo. *Offered: winter term.*

SPA556: SPANISH NONFICTION

Students continue to develop their linguistic skills while exploring nonfiction topics through a variety of sources including essays, newspapers, memoirs, documentaries, articles, podcasts, films, comics, etc. The course allows for the study of a wide variety of issues such as the historical, political and cultural landscape of Latin America and Spain, from colonial times to current events. Topics encountered in previous courses, such as independence movements, the struggle for democracy and social justice, the dynamics of socioeconomic class, religion, globalization, changing family and gender dynamics, and immigration, may be explored in this course. *Offered: spring term.*

SPA557: HISPANIC CINEMA

The readings, discussions and writing in this course will center on a series of Hispanic films chosen for their cultural, historical and artistic value. Students will read scenarios, source material or summaries of the films, and they will discuss and write about characterization, plot, themes, and geographical and cultural aspects. *This course meets during the reserve format to allow for film viewing. Offered: winter term.*

SPA558: SPANISH THROUGH DIGITAL MEDIA

This course is designed to emphasize the continued development of the four language skills, reading, writing, listening and speaking — focusing more on the last two — by viewing and discussing podcasts, video talks, documentaries and short films, among other possibilities available online and in other media. In their daily preparation, students should expect to examine a wide range of topics from a variety of regions in the Hispanic world. Our study will provide an informative window for current events and cultural trends and the variety of speaking accents, lexicons and idiomatic traits of Latin America, Equatorial Guinea and Spain. *Offered: fall term.*

SPA570: SOCIO-LINGUISTIC EXPLORATION THROUGH TV SERIES IN SPANISH

This course is designed to learn about the culture of Spanish-speaking countries through an exploration of TV series. Students will view, discuss, analyze and present on different aspects, including but not limited to identity, community, art and history. The course may also include reading of written material serving as the basis for these series. Exposure to authentic audio will allow students to develop a better understanding of spoken Spanish as well as provide a wider range of authentic vocabulary as it is used in everyday situations. In place of a text, students must subscribe to a video platform for the duration of the term. *Prerequisite: any 500-level Spanish course. Offered: spring term.*

SPA590: SELECTED TOPICS IN SPANISH

These courses are offered at student or departmental initiative and may change from year to year. In 2026-27, two SPA590 courses, detailed below, will be offered.

SPA590: POPULAR CULTURE IN THE HISPANIC WORLD

In this course, students will explore and deepen their knowledge of various aspects of Hispanic society through topics in popular culture. Among the possible subjects to be examined throughout the four themes that comprise this course are soccer, soap operas, music, comics, food, festivities, social protest and cultural icons. In this class, students will have the opportunity to analyze and critically reflect on specific phenomena that explain aspects of the Spanish-speaking world. *Prerequisite: any 500-level Spanish course. Offered: fall term.*

SPA590: SOUND, BEAT AND SENSE: THE HISPANIC WORLD THROUGH ITS MUSIC

Sound, beat and sense (*son, latido y sentido*) — “*son*,” a pleasant music to your ears; “*latido*,” your heart beating; and “*sentido*,” a sense of meaning. ...

The first known literature in the Spanish language dates back to the 11th century, and it was highly lyrical. A thousand years later, contemporary music and poetry in Spanish are among the most popular in their genre in the 21st century. This course seeks to help students understand cultural, social or political aspects of the Spanish-speaking world by focusing on different musical phenomena and the historical context in which they were developed. To achieve this, the course will include readings and audiovisuals relating to genres, movements, authors or other aspects related to music. We will focus on the analysis of the structure, meanings and cultural nuances of representative songs, musical pieces and styles. Students will do research and write analyses of works studied while in an environment that will foster creativity and provide a space for possible poetical and musical creations. *Prerequisite: any 500-level Spanish course. Offered: spring term.*

Music

Music engages our deepest faculties of listening, reasoning, imagining and feeling. The study of music is a fundamental part of a well-rounded education. An essential way to explore our common humanity, music simultaneously cultivates self-discovery and empathy. An experience rich in musical challenge and reward teaches lessons that extend beyond the classroom, studio or concert hall.

For students of any level of experience or area of musical interest, there is an appropriate point of entry to the curriculum. Our program is realized through three areas of study: performing ensembles, private lessons and the academic classroom. In ensembles, students learn the art of collaborative music-making and listening. Students taking private lessons explore technique, interpretation and self-expression. In the classroom, students study the theoretical, historic and cultural contexts that awaken interest in, and understanding of, the musical language. The fullest educational experience combines study in all three areas to develop musically literate students who will be engaged in music throughout their lives.

The department seeks both to instruct students in music and to enrich the life of the school through performance and community engagement, giving voice to a common spirit in times of occasion; a powerful expression of *non sibi*.

We engage students and audiences with the intention of realizing the inherent value of different styles of music, the cultures and artists from which they originate, and the processes by which they are performed and created. We acknowledge the educational, artistic and cultural importance of broadly representational, intentionally diverse choices in repertoire for both pedagogy and public performance. We seek to continuously expand the musical vocabulary of our students and audiences in this regard and to use our resources to provoke new works that amplify new voices.

■ Musical Language, Creation and Analysis

MUS050: MODERN MUSIC MAKING

This course is a workshop for students interested in making modern styles of music, primarily through technology. Students will develop their technique, their aesthetic and their ears by working on multiple collaborative and independent projects across a spectrum of musical genres including (but not limited to) pop, hip-hop, EDM, ambient and experimental. There will also be opportunities for live performances, cross-disciplinary collaboration and student-initiated projects. The in-class studio environment will be one of creativity, curiosity and collaboration as students work both

together and alongside each other in pursuit of their musical goals. *Provides 1/3 credit per term. See “Endnotes” for important information regarding diploma credit, repeating courses and the “Credit Option.” Meets three class periods per week. No audition required. Students do not need to know how to read music.*

MUS200: INTRODUCTION TO MUSIC THEORY

This introductory course is designed to introduce students to the basics of reading, writing, hearing and creating music, focusing on Western notation of rhythm and pitch, including scales, intervals, and major and minor keys and chords. Students will study and listen to music from a variety of traditions. The practical skills of ear training, sight-singing and dictation are integrated into the course. As this is an introductory-level course, there is no prerequisite; students enrolled should have either minimal or no prior experience with music theory. *Provides one term of credit toward the studio/performance arts requirement. Open to all students. Offered fall and spring terms.*

MUS206: MUSICAL STRUCTURE AND SONGWRITING

This course approaches contemporary songs and songwriting from both analytical and creative perspectives, engaging with music from a broad spectrum of genres, styles, influences and eras. Until midterm, students will study the structures and practices of songwriting through detailed analyses that focus on aspects of structure, instrumentation and production, and lyric content. In the remainder of the term, students will create their own work through a series of solo and collaborative songwriting assignments, inviting a variety of styles and flavors of musical expression. Prior experience with music theory and notation is not a requirement for success in this course. Students interested in all musical genres are welcome; however, it is expected that all students will be capable and willing to perform at a basic level using their own voice and/or an instrument and/or technology. *Provides one term of credit toward the studio/performance arts requirement. Offered: fall term.*

MUS410: MUSIC THEORY FOR MUSICIANS

Students in this course continue their study of the language of music by creating short compositions, which are performed in class. They learn to use the elements of music in melody writing, text setting and harmonization and also explore the fundamentals of consonance and dissonance in two-, three- and four-part writing. Finally, the interaction of harmony and counterpoint is examined. Analysis of selected works supplements and informs the students' own creative work. In addition, students continue to develop their aural comprehension, sight-singing and keyboard skills. *Provides one term of credit toward the studio/performance arts requirement. Prerequisite: MUS200 or permission of the department. Offered: winter term.*

MUS440: ADVANCED MUSIC PRODUCTION

This course provides advanced instruction for students interested in improving their mastery of digital music production. Students will explore production techniques, project development and creative practice. Students with interests in all musical genres are encouraged to register. Students must have previous experience producing music in a digital audio workstation (DAW). *Provides one term of credit toward the studio/performance arts requirement. Prerequisite: MUS050 or permission of the department. Offered: spring term.*

■ **Music History and Appreciation**

MUS203: LISTENING TO MUSIC

This introductory course is intended for students who want to expand their knowledge of music and become informed listeners. No prior musical training is required. Students will learn to perceive the elements of music — rhythm, melody, harmony, texture, timbre and form and acquire a musical vocabulary to describe what they hear. This course will explore music across boundaries of culture, style and time — classical and popular, Western and non-Western, traditional and experimental, folk and jazz, and consider the influence of technology on the art of music. Course work will include listening assignments, reading, reflections and attendance at concerts. *Provides one term of credit toward the completion of the arts requirement. Open to all students. Offered: winter term.*

MUS207: MUSIC OF CONFLICT, UPRISING AND PROTEST

In what ways and under what circumstances does music serve a moral purpose? How has music been used to articulate and amplify experience, aspiration and memory in uncertain and unstable times? How is the experience of oppressed peoples channeled through music? This course seeks to examine how people experiencing conflict, injustice and oppression respond with music. We will also examine the cultural, historical and political contexts in which this music was created. *Provides one term of credit toward the studio/performance arts requirement. Open to all students. Offered fall term.*

MUS208: AMERICAN POPULAR MUSIC: THE BLUES TO WOODSTOCK

In this course, students will study selected topics in the history of popular music in America in the years 1900-1969. Beginning with the Blues and ending up at the end of the tumultuous decade of the 1960s, students will examine both the music and the musicians who made it, as well as the cultural and political landscapes in which the music was made. Emphasis will be placed on aural recognition of significant recordings from a wide variety of genres, focusing on familiarity with artists, eras, musical styles and historical background. *Provides one term of credit toward the completion of the studio/performance arts requirement. Open to all students. Offered: winter term.*

MUS209: AMERICAN POPULAR MUSIC: PUNK TO HIP-HOP

In this course, students will study selected topics in the history of popular music in America in the years 1970-present. Beginning with

the emergence of American punk music at the beginning of the 1970s and ending up at the present, students will examine both the music and the musicians who made it, as well as the cultural and political landscapes in which the music was made. Emphasis will be placed on aural recognition of significant recordings from a wide variety of genres, focusing on familiarity with artists, eras, musical styles and historical background. *Provides one term of credit toward the completion of the studio/performance arts requirement. Open to all students. Offered: spring term.*

■ **Performance**

See “Endnotes” for important information regarding diploma credit, registration, auditions, repeating courses and the “Credit Option.”

MUS400: ADVANCED INSTRUMENTAL/VOCAL STUDY I

This is a performance course for qualified students who wish to devote one term to intensive study of their instrument or voice. With the guidance of their instructor, students work on technique and interpretation with the goal of developing their own musical voices. Students participate in twice-weekly performance classes where emphasis is placed on developing effective practice techniques and understanding the style and expression of the music they are studying. Students are required to perform in student concerts such as the Student Showcase. Students taking MUS400 must take weekly private lessons. Permission may be granted by the department for students studying with teachers outside the Academy to take MUS400. *Provides one term of credit toward the studio/performance arts requirement. This course may be repeated for credit. Prerequisite: Requires permission of the Music Department. An application must be submitted to the department chair with a recommendation by the private instructor. One private lesson and two studio classes per week. Offered: spring term.*

MUS500: ADVANCED INSTRUMENTAL/VOCAL STUDY II: RECITAL

This intensive performance course for advanced instrumentalists and vocalists culminates in a public solo recital. In twice-weekly classes, students perform for each other, receive constructive feedback, and address questions and strategies relating to practice and public performance. Students in MUS500 must take private lessons. Permission may be granted for students studying with teachers outside the Academy to take MUS500. An application must be submitted to the department chair with a recommendation by the private instructor. A proposed program (with timing) must be included in the application. Applications are due in early January. Approval will be based on the following criteria:

- › A MUS500 recital should have approximately 30-45 minutes of music.
- › Programs should include repertoire from a range of musical styles and a variety of historical periods and composers.
- › Programs should balance the technical demands of the music and the student’s technical ability.
- › Concertos are discouraged.

Provides one term of credit toward the studio/performance arts requirement. This course may be repeated for credit. Prerequisite: requires permission of the Music Department and successful previous performing experience. One private lesson and two studio classes per week. Offered: spring term.

PEC110: ADVANCED MUSIC PRACTICE

This course provides regular practice and/or creative time for dedicated music students within the context of Exeter’s academic schedule. Students meet at a common time in the afternoon to practice under the supervision of the music faculty. Time is also reserved for physical activity, including cardiovascular exercise, core and flexibility training, and exercises to avoid repetitive-stress injuries.

PEC110 does not carry academic credit but meets the physical education requirement for the term. This course is limited to 13 students each term and is not open to 9th graders in the fall term. Students must complete an application describing their musical goals for this course, and there is no guarantee of acceptance based on previous participation.

■ Private Lessons

MUS010: PRIVATE LESSONS

Private music lessons offer students an individualized learning experience with a private instructor. In the lessons, students develop technique and expression, while they explore the repertoire for their instrument. Students receive one 50-minute lesson per week and are expected to practice independently between lessons. Provides 1/3 credit per term. See “Endnotes” for important information regarding diploma credit, repeating courses and the “Credit Option.”

Note on Private-Lesson Fees

Private lessons are billed **in addition** to tuition. Students on financial aid receive partial scholarship for private lesson fees for one set of lessons per term.

Students normally receive 10 lessons per term. At least 8 lessons are required to pass this course.

■ Ensembles

See “Endnotes” for important information regarding diploma credit, registration, auditions, repeating courses and the “Credit Option.”

MUS011: GLOBAL RHYTHM ENSEMBLE

In group classes, students learn the basic playing techniques of the steel drums and other instruments from around the world. Players develop their melodic, harmonic and rhythmic skills and sense of ensemble while experiencing the special energy and excitement of playing together. Students do not need previous musical experience to join this ensemble. Participation in all performances is required. Provides 1/3 credit per term. See “Endnotes” for important information regarding diploma credit, repeating courses and the “Credit Option.” One evening session per week plus individual practice. No audition required.

MUS050: MODERN MUSIC MAKING

See description on page 51.

MUS060: INSTRUMENTAL CHAMBER MUSIC

Students receive weekly coaching in trios, quartets, quintets and other small ensembles and experience the special give-and-take of playing chamber music. Instrumental combinations include strings, winds, brass, piano, percussion and harp. Students develop the musical and collaborative skills needed for effective rehearsal and communicative performance while acquiring stylistic awareness. Chamber music ensembles perform throughout the year. Every effort is made to place students, although placement in a group is not guaranteed. Provides 1/3 credit per term. See “Endnotes” for important information regarding diploma credit, repeating courses and the “Credit Option.” Placement audition required.

MUS070: VOCAL CHAMBER MUSIC

Students are placed in small ensembles to sing a variety of historical and contemporary vocal styles and literature. Students learn the tenets of singing in a small ensemble and work on vocal production, diction, intonation and performance practice. Vocal Chamber groups perform throughout the year. Provides 1/3 credit per term.

LESSONS ARE OFFERED FOR THE FOLLOWING INSTRUMENTS:

Bagpipes	Drum Set	Harp (Classical, Irish)	Trumpet
Banjo	Electric Bass	Oboe	Tuba
Baritone	Euphonium	Organ	Ukulele
Bassoon	Fiddle	Percussion	Viola
Cello	Flute (Classical, Wooden Celtic)	Piano (Classical, Jazz)	Violin
Clarinet	French Horn	Saxophone (alto, baritone, tenor)	Voice
Composition	Guitar (Classical, Folk, General, Jazz, Rock)	Trombone	
Double Bass (Classical, Jazz)			

See “Endnotes” for important information regarding diploma credit, repeating courses and the “Credit Option.” Placement audition required.

Ensembles offered may include:

- › Gli Scalatori (Italian madrigals)
- › New Music Ensemble
- › Renaissance Schola
- › Vocal Jazz

Other groups form each term as enrollment and interest dictate.

MUS075: EXETER CHORAL UNION

Open to all students without an audition, this mixed-voice choral ensemble performs works of choral literature from many traditions and style periods. Through twice-weekly rehearsals, students develop their vocalism, musicianship and choral skills. The Choral Union performs regularly throughout the year. *Provides 1/3 credit per term. See “Endnotes” for important information regarding diploma credit, repeating courses and the “Credit Option.” Two evening rehearsals per week. No audition required. Membership in the Exeter Choral Union is expected for the full academic year, with exceptions for special circumstances such as scheduling conflicts.*

MUS077: CONCERT CHOIR

Concert Choir offers a rigorous choral experience to those students accepted by audition. The choir performs a wide variety of choral literature representing many traditions and style periods. Through intensive rehearsals and public performance, students develop their vocalism, musicianship and choral skills. The Concert Choir performs regularly throughout the year. *Provides 1/3 credit per term. See “Endnotes” for important information regarding diploma credit, repeating courses and the “Credit Option.” Open to 10th, 11th and 12th graders. Meets three class periods per week. Audition required. Membership in the Concert Choir is expected for the full academic year, with exceptions for special circumstances such as scheduling conflicts.*

MUS083: EXETER SYMPHONIA

The Symphonia provides a foundation orchestral experience for students at the intermediate level. The fundamental techniques of orchestral playing, musicianship and ensemble performance are developed through the study of music from diverse styles and periods. The Symphonia performs regularly throughout the school year. *Provides 1/3 credit per term. See “Endnotes” for important information regarding diploma credit, repeating courses and the “Credit Option.” Two evening rehearsals per week. Placement audition required. Membership in the Exeter Symphonia is expected for the full academic year, with exceptions for special circumstances such as scheduling conflicts.*

MUS085: SYMPHONY ORCHESTRA

The PEA Symphony Orchestra of advanced instrumentalists rehearses and performs works from the major symphonic repertoire, including works by living and under-represented composers, and collaborates with the student soloist winners of the annual PEA

Concerto Competition. All aspects of orchestral technique and style are studied through both full and sectional rehearsals. The Symphony Orchestra performs regularly throughout the year. *Provides 1/3 credit per term. See “Endnotes” for important information regarding diploma credit, repeating courses and the “Credit Option.” Two evening rehearsals per week. Audition required. Membership of Symphony Orchestra is expected for the full academic year, with exceptions for special circumstances such as scheduling conflicts.*

MUS087: CHAMBER ORCHESTRA

The Chamber Orchestra offers an intensive ensemble experience for advanced string and woodwind players. The skills, craft and discipline of orchestral playing are developed in-depth through the study of repertoire for small orchestra. We explore music from a wide range of styles — Baroque Concerti Grossi, Classical period symphonies, Romanic pieces, the rich small orchestra repertoire of the 20th century, and the growing body of exciting and diverse works by living composers. The Chamber Orchestra performs regularly throughout the year, often collaborating with the Exeter Choral Union and Concert Choir. All members of the Chamber Orchestra also play in the Symphony Orchestra or participate in another large ensemble. *Provides 1/3 credit per term. See “Endnotes” for important information regarding diploma credit, repeating courses and the “Credit Option.” Meets three class periods per week. Audition required. Membership of Chamber Orchestra is expected for the full academic year, with exceptions for special circumstances such as scheduling conflicts.*

MUS093: PEA BAND

The PEA Band is an opportunity for wind, brass, percussion and electric instrument players of all levels and abilities to study and perform music together. The PEA Band operates as a concert band, primarily performing standard and contemporary band literature. In the winter, when possible, the ensemble may also operate as a pep band allowing students to perform in the stands at select athletic events. Through rehearsals and performances, students improve their technical and ensemble skills as well as their sensitivity to musical nuance and their ability to listen to and relate their individual parts to the whole. Participation in all performances is required. *Provides 1/3 credit per term. See “Endnotes” for important information regarding diploma credit, repeating courses and the “Credit Option.” Two evening rehearsals per week plus individual practice. Open to all students with basic musical proficiency. No audition required. Membership in the PEA Band is expected for the full academic year, with exceptions for special circumstances such as scheduling conflicts or participation in an interscholastic sport.*

MUS095: JAZZ AND CONTEMPORARY SMALL ENSEMBLES

These combos, bands and other small ensembles give intermediate and advanced musicians the opportunity to develop their ensemble and improvisational skills through the study of jazz and other contemporary repertoire in a smaller group setting. Emphasis will be placed on the fundamentals of establishing groove, balance, nuance, tone and other ensemble skills necessary to develop musicianship. These ensembles perform regularly throughout the

school year. Participation in all performances is required. *Provides 1/3 credit per term. See “Endnotes” for important information regarding diploma credit, repeating courses and the “Credit Option.” Placement audition required. Membership in these ensembles is expected for the full academic year, with exceptions for special circumstances such as scheduling conflicts.*

MUS097: PEA JAZZ ENSEMBLE

The PEA Jazz Ensemble offers advanced students the opportunity to experience jazz performance in a big band setting. The ensemble performs traditional and contemporary jazz repertoire, allowing students to learn performance and improvisational techniques in the style of the jazz greats. The Jazz Ensemble performs throughout the year. Participation in all performances is required. *Provides 1/3 credit per term. See “Endnotes” for important information regarding diploma credit, repeating courses and the “Credit Option.” Meets three class periods per week. Placement audition required. Membership in the PEA Jazz Ensemble is expected for the full academic year, with exceptions for special circumstances such as scheduling conflicts.*

■ Endnotes

Diploma Credit for Partial Credit Courses

One full credit is granted upon completion of three consecutive terms of study in the same 1/3 credit course and may be applied toward the performing/studio arts diploma requirement. The consecutive terms may be interrupted with permission from the department.

Additional stipulation for students entering the Academy in 2025 or later: A maximum of one credit total may be applied from the following courses toward the performing/studio arts diploma requirement: MUS010, MUS060, MUS070 and MUS095.

Registration for Performance Courses

Students who register for MUS400 or MUS500 must also register for private lessons. The private lessons taken as part of MUS400 or MUS500 are part of the course and do not provide any additional partial credit. Permission for students to substitute off-campus lessons for MUS010 as part of MUS400 or MUS500 will be given by the department on a case-by-case basis.

Repeating Courses

MUS400, MUS500, Private Lessons and Ensembles may be repeated.

The Credit Option

Any student taking the same 1/3 credit music course for three consecutive terms may take a one-course reduction in load during the third term.

This reduction, known as the Credit Option, should be communicated to the scheduler at the time of registration. See page 1 for more details.

Instrumental Auditions

All instrumentalists, including pianists, must take a placement audition for Symphony Orchestra, Symphonia, Chamber Orchestra, Chamber Music, Jazz Ensemble and Contemporary Small Ensembles at the beginning of the fall term.

Physical Education and Athletics

Phillips Exeter Academy provides a comprehensive physical education program for all students, supervised by the director of Physical Education and Athletics. Students may fulfill the physical education requirement by taking a physical education class or participating on an interscholastic athletic team. Ninth graders are required to participate all three terms, either by making a team or through the 9th-Grade Physical Education Program (PEC111). Tenth, 11th and 12th graders are encouraged to participate all three terms but may take one term off using “Choice Format” (see addendum at the end of this section).

Students can expect to devote one hour four times per week to a physical education class. Interscholastic athletic teams require participation six days per week, which includes contests on many Wednesdays and Saturdays. Please note that specific scheduling requests for physical education classes are not allowed.

PEC111: 9TH-GRADE PHYSICAL EDUCATION PROGRAM

The 9th-Grade Physical Education Program is a specifically designed physical education offering required of all 9th graders. Each of the three terms is discrete. Exceptions include earning a roster spot for an interscholastic team, a dance class or a mainstage theater production. Please sign up for PEC111 if entering the 9th grade. Changes will be made automatically in a term where a student makes any of the above rosters.

The 9th-Grade Physical Education Program provides an opportunity for Exeter's newest students to have the team of physical education instructors and the extensive athletic facilities all to themselves. The foundation of the program is built on community, inclusivity, safety, equity, encouragement and enthusiasm. Virtually everything that is offered as a full-term physical education course or interscholastic sport for 10th- through 12th-graders is offered in "sampler form" to 9th graders.

■ Fall Interscholastic Programs

Please visit www.weareexeter.com for more details about each sport and information on contacting coaches.

PEB110: BOYS V/JV CROSS COUNTRY

PEG110: GIRLS V/JV CROSS COUNTRY

PEG120: GIRLS VARSITY FIELD HOCKEY

PEG125: GIRLS JV FIELD HOCKEY

PEM130: VARSITY FOOTBALL

PEM135: JV FOOTBALL

PEG140: GIRLS VARSITY VOLLEYBALL

PEG145: GIRLS JV VOLLEYBALL

PEG146: GIRLS JV2 VOLLEYBALL

PEB160: BOYS VARSITY SOCCER

PEB165: BOYS JV SOCCER

PEB166: BOYS JV2 SOCCER

PEG160: GIRLS VARSITY SOCCER

PEG165: GIRLS JV SOCCER

PEB180: BOYS VARSITY WATER POLO

PEB185: BOYS JV WATER POLO

PEM190: VARSITY MOUNTAIN BIKING

PECMGR: V/JV TEAM MANAGER

Students can serve as managers of a JV team, varsity team or the Athletic Department. Students who wish to manage must get approval from the head coach and/or the Athletic Office prior to

the start of the term. Expectations for managing vary from team to team and from sport to sport. Managers may be required at daily practices, as well as home and away contests. Duties may include operating a score clock, equipment setup, keeping a scorebook, filming, social media posting, etc. An independent physical activity program is an expectation. *Open to 10th, 11th and 12th graders.*

■ Fall Physical Education Programs

PEC109: THEATER PRODUCTION WARMUP

See Theater and Dance offerings.

PEC110: ADVANCED MUSIC PRACTICE

See Music offerings.

PEC304: AMERICAN RED CROSS LIFEGUARDING

The purpose of the American Red Cross Lifeguarding course is to provide entry-level participants with the knowledge and skills to prevent, recognize and respond to aquatic emergencies and to provide care for breathing and cardiac emergencies and sudden illnesses until emergency medical services (EMS) personnel arrive and take over. To successfully complete this course and be granted the two American Red Cross Certifications in Lifeguarding/First Aid and CPR/AED for the Professional Rescuer (valid for two years), you must attend all class periods; participate in all skills sessions/drills, activities and scenarios; demonstrate competency in all required skills and scenarios; and pass the final written exam with a minimum grade of 80 percent.

PEC330: PE GIRLS CREW

PEC331: PE BOYS CREW

Fall crew is open to both novices and experienced rowers. Novices are introduced to rowing and coxing in eight-oared shells after a review of boatmanship and water safety. By midseason, they are ready to participate in intramural races. Novices who progress rapidly can become candidates for the varsity crews in the spring. Experienced rowers and coxswains place emphasis on improving individual technique and aerobic conditioning at low cadences in fours and eights. All look forward to occasional intramural 3-mile races and our annual 500-meter Class Day Regatta. Practices occur, on average, four days per week, including some Wednesdays. *Students must pass the crew-specific swim test in order to participate.*

PEC411: 10TH-, 11TH- AND 12TH-GRADE PHYSICAL EDUCATION PROGRAM

The 10th-, 11th- and 12th-grade Physical Education Program is designed to give our students the opportunity to pursue areas of strong interest and explore new experiences. The program has a wide range of offerings to expose our students to lifelong pursuits, adventure activities and traditional sports. The fall program offers crew, tennis, stand-up paddleboard, flag football, walking,

yoga, soccer, tennis, field hockey, mountain biking, strength and conditioning, learn to swim, running and volleyball. Students are scheduled into a PE format and then select two activities from the list, one for each half of the term. Students may repeat an activity in the second half of the term if space and staffing allow. It may not be possible for all students to get their first choice for both sessions; however, we will make every attempt to enroll students in a preferred activity in at least one of the sessions. *Offered: fall term.*

DANCE

See Theater and Dance offerings.

■ Winter Interscholastic Programs

Please visit www.weareexeter.com for more details about each sport and information on contacting coaches.

PEB210: BOYS VARSITY BASKETBALL

PEB215: BOYS JV BASKETBALL

PEG210: GIRLS VARSITY BASKETBALL

PEG215: GIRLS JV BASKETBALL

PEB250: BOYS VARSITY HOCKEY

PEB255: BOYS JV HOCKEY

PEG250: GIRLS VARSITY HOCKEY

PEG255: GIRLS JV HOCKEY

PEB260: BOYS V/JV SQUASH

PEG260: GIRLS V/JV SQUASH

PEB270: BOYS VARSITY SWIMMING

PEB272: BOYS V/JV DIVING

PEB275: BOYS JV SWIMMING

PEG270: GIRLS VARSITY SWIMMING

PEG272: GIRLS V/JV DIVING

PEG275: GIRLS JV SWIMMING

PEB280: BOYS V/JV TRACK

PEG280: GIRLS V/JV TRACK

PEM290: V/JV WRESTLING

PECMGR: V/JV TEAM MANAGER

See fall program description.

■ Winter Physical Education Programs

PEC109: THEATER PRODUCTION WARMUP

See Theater and Dance offerings.

PEC110: ADVANCED MUSIC PRACTICE

See Music offerings.

PEC411: 10TH- 11TH- AND 12TH-GRADE PHYSICAL EDUCATION PROGRAM

The 10th-, 11th- and 12th-grade Physical Education Program is designed to give students the opportunity to pursue areas of strong personal interest while also exploring new experiences. The program offers a broad range of activities intended to expose students to lifelong pursuits, outdoor exploration, fitness-based training and traditional sports. During the winter term, offerings may include skating, basketball, strength and conditioning, indoor cycling, outdoor exploration, yoga, hockey, squash, and additional activities based on interest and facility availability. Students are scheduled into a PE format and select two activities from the list, one for each half of the term. Students may repeat an activity in the second half of the term if space and staffing allow. While it may not be possible for all students to receive their first choice for both sessions, every effort will be made to enroll students in a preferred activity for at least one half of the term. *Offered: winter term.*

DANCE

See Theater and Dance offerings.

■ Spring Interscholastic Programs

Please visit www.weareexeter.com for more details about each sport and information on contacting coaches.

PEB280: BOYS V/JV TRACK

PEG280: GIRLS V/JV TRACK

PEB300: BOYS VARSITY VOLLEYBALL

PEB305: BOYS JV VOLLEYBALL

PEB310: BOYS VARSITY BASEBALL

PEB315: BOYS JV BASEBALL

PEG310: GIRLS VARSITY SOFTBALL

PEG315: GIRLS JV SOFTBALL

Not offered in 2026-27.

PEB330: BOYS V/JV/NOVICE CREW

PEG330: GIRLS V/JV/NOVICE CREW

PEM350: VARSITY GOLF

PEB360: BOYS VARSITY LACROSSE

PEB365: BOYS JV LACROSSE

PEG360: GIRLS VARSITY LACROSSE

PEG365: GIRLS JV LACROSSE

PEB370: BOYS VARSITY A/B TENNIS

PEB375: BOYS JV TENNIS

PEG370: GIRLS VARSITY A/B TENNIS

PEG375: GIRLS JV TENNIS

PEG380: GIRLS VARSITY WATER POLO

PECMGR: V/JV TEAM MANAGER

See fall program description.

■ Spring Physical Education Programs

PEC104: YOGA AS MEDITATION

PEC106: VINYASA YOGA

Yoga at Exeter is taught in several ways, and choosing one is a matter of preference. Yoga is an individual practice, and all students are welcome regardless of previous experience. In both types of yoga, joints, muscles and internal organs benefit from movements that stimulate often-neglected areas of the body. You can expect to improve overall mobility, strength and balance and will probably enjoy stress reduction and a greater sense of well-being, too. Yoga as meditation, a style sometimes referred to as “gentle yoga,” focuses on learning and holding classic asanas (poses), working with the breath (pranayama) and practicing meditation skills in a calm and peaceful environment, allowing the mind and body to quiet. Vinyasa yoga is for the student who is seeking the same overall benefits as listed above but through a more active sequence of movements.

PEC108: PE FENCING

Not offered in 2026-27.

PEC109: THEATER PRODUCTION WARMUP

See Theater and Dance offerings.

PEC110: ADVANCED MUSIC PRACTICE

See Music offerings.

PEC131: ULTIMATE FRISBEE

This ultimate Frisbee program is designed to develop basic skills through practices and intramural team play. It provides an

enjoyable game for students of any level of experience. There is an opportunity for competition with other schools.

PEC171: PE TENNIS

PE tennis is designed for both beginning players and those who desire one-on-one competitive match play. Players are evaluated at the beginning of the term and sectioned into smaller groups based on ability and experience. This section is open to students who have not participated in the varsity or junior varsity programs. Players compete in singles and doubles through round-robin and/or team play. PE coaches also conduct team practices in singles and doubles and/or team matches. Free-hit days are also scheduled into the section. Spring PE tennis sections may also play matches against the 9th-Grade PE Program competitive tennis section.

PEC175: PE BADMINTON

The course will teach the fundamental skills of badminton. During the term students will learn basic strokes, the rules of the game, history of the sport, scoring and etiquette. Students will participate in singles and doubles matches while also learning strategies of the game.

PEC205: THE PRINCIPLES OF FITNESS

The Principles of Fitness course is designed for students of all physical abilities. The goal of this course is to provide students with lifelong fitness habits. Students will gain an understanding of the effects of exercise on health and well-being while being able to apply the learned skills to their everyday life. This will be accomplished by introducing students to facilities, equipment and resources that are available on campus. Topics will include resistance training, cardiovascular fitness, warm-up/cool-down, plyometrics and flexibility. Classes will be built around individual and group workouts.

PEC304: AMERICAN RED CROSS LIFEGUARDING

See fall program description.

PEC340: PE CYCLING

This course is open to students who have not participated in the varsity cycling program. Though not a racing activity, it increases ability and stamina. Rides around Exeter vary from 8 to 15 miles, with occasional longer rides. Bikes and helmets are provided by the department.

PEC350: PE GOLF

In the PE golf program, approximately 13 students play four days a week at the Exeter Country Club.

DANCE

See Theater and Dance offerings.

■ Addendum

Enrollment in **PECEXC** and **PECTEX** are exceptional cases determined by the student's adviser, the Physical Education Department, the Lamont Health and Wellness Center and/or the Dean of Students Office. Enrollment in the following courses can be in the fall, winter or spring terms.

PECEXC: ACTIVITY EXCUSED

This is for students unable to participate in the physical education program due to a medical condition. Permission of the Academy's health care staff is required.

PECTEX: THERAPEUTIC EXERCISE

This course is for students who have a physical limitation that precludes them from participating in any formal physical education course offering but are able to do a modified exercise program with the supervision of an athletic trainer and/or strength and conditioning

coach. A personal exercise plan will be created for students to attain a specific physical benefit, such as maintenance of the range of motion, strengthening of weakened muscles, increased joint flexibility, or improved cardiovascular and respiratory function. Participation in this course is determined by medical necessity and must be approved by the Academy's health care staff.

CHF001: CHOICE FORMAT

Lower, uppers and seniors may select Choice Format in up to one term each year if they take a physical education or athletics offering in each of the other two terms. Choice Format is usually scheduled in the final format(s) of the academic day. *Choice Format is not allowed for students who will participate in an off-campus program at any point in the current school year, unless that program has a preapproved program of physical education. Open to 10th, 11th and 12th graders.*

Psychology

PSY550: INTRODUCTION TO PSYCHOLOGY

Students in this course study a range of explanations for human thought, behavior and emotion. Readings, projects and class discussions facilitate exploration of a variety of topics in this fascinating and evolving field, ranging from historical figures such as Freud to cutting-edge neuroscience research. Specific areas of focus include the nervous system and brain functions; human development (with a primary focus on the teenage brain); questions

of nature versus nurture; social psychology and group dynamics; and the diagnosis and treatment of mental illness, psychopathology and addiction. Independent research allows students to explore specific topics of interest, such as a self-study of the impact of their sleep patterns and screen usage on their academics, mental health and physical/emotional well-being. *Open to 11th and 12th graders. Note: This course does not provide credit toward the religion, ethics and philosophy requirement.*

Religion, Ethics and Philosophy

The Department of Religion, Ethics and Philosophy welcomes Exonians to academic study of life's formative questions and the world's formative traditions. Courses study the diversity of religions, philosophies and ethical systems that have oriented human efforts to live well. In doing so, they offer students opportunities to examine the forces, ideas and stories structuring our shared worlds, to better understand their lived experience, to reflect on current events from a historical

perspective, and together to raise possibilities for a more just future.

Course offerings are distinctive and interdisciplinary. Each course invites students into questions of meaning, value and purpose. In doing so, the courses deepen skills for careful reading, critical thinking, analytical writing and metacognition. Whether through the study of Zen Buddhist teachings and practices, analysis of the religious images and

themes that inform U.S. popular culture and music, or ethical reflection on the global economy, emerging technologies and the ecological crisis, courses celebrate creativity and intellectual curiosity. Ultimately, courses are designed to cultivate students' capacity for cross-cultural engagement and responsible participation in community at the Academy and throughout their wider worlds.

The Religion, Ethics and Philosophy Department endorses Exonians' elective freedom. There are no prerequisites for courses in Religion, Ethics and Philosophy; courses may instead be taken in any order appropriate to grade level. Students decide their own path according to their interests.

As a department, the faculty of Religion, Ethics and Philosophy is committed to practicing the unity of knowledge and goodness. We strive to cultivate learning spaces where students come together to consider existential questions with sensitivity, perspective and compassion.

■ Courses by Focus of Inquiry

Religion: If you are interested in learning about the religions of the world, their histories, and their grounding beliefs, practices and institutions, these courses in the academic study of religion are for you. The courses offer an introduction to a diversity of religious traditions, their histories and their place in the contemporary world. They also will deepen your skills for relating with one another across different religious identities and commitments.

REL250, 255, 260, 265, 270, 350, 355, 360, 365, 470, 530, 535, 540, 545, 565, 570, 575

Ethics: Ethics concerns the moral principles and systems of value that guide our actions and shape our relationships. If you are interested in thinking about what is morally right or wrong, questions of duty and justice, or what you should or should not do in different situations, consider courses in this area. These courses will introduce you to a range of ethical theories, frameworks and practices in the context of contemporary political, economic and ecological scenarios. In the process, you will have the opportunity to contemplate, articulate and assess your own ethical commitments, as well as their effects.

REL265, 450, 455, 460, 480, 530, 535, 540, 560, 570, 580

Philosophy: It is written that Socrates once said, "The unexamined life is not worth living." If you are interested in thinking with others about life's "big questions" — like, How do I know what I know? And, Why does evil exist? Or, What is the meaning of life? — these courses are designed with you in mind. Encouraging curiosity and intellectual humility, these courses will introduce you to the world's philosophies, while offering you the opportunity to hone your logic, critical reasoning, constructive reflection and argumentation skills.

REL270, 460, 470, 480, 530, 535, 540, 545, 555, 560, 565, 570, 575, 580

■ Courses by Grade Level

9th graders: REL250, 255, 260, 265, 270, 290, 350, 355, 360, 365

10th graders: REL250, 255, 260, 265, 270, 290, 350, 355, 360, 365

11th graders: REL350, 355, 360, 365, 450, 455, 460, 470, 480, 530, 535, 540, 545, 555, 560, 565, 570, 580

12th graders and postgraduates: REL450, 455, 460, 470, 480, 530, 535, 540, 545, 555, 560, 565, 570, 575, 580

The course in psychology, an affiliated course under the aegis of the Religion, Ethics and Philosophy Department, is listed above.

REL250: HEBREW BIBLE/OLD TESTAMENT

"In the beginning, God created the heavens and the earth. ..." So begins one of the most influential sacred texts in human history. From ancient times until the present, Jews, Christians and Muslims have grappled with the cosmic questions, universal myths, compelling laws and dramatic narratives of the Hebrew Bible, also known as the Old Testament. It is a collection of texts that is both timeless and timely. In this course, students will gain an appreciation of the historical, political and social context from which the Hebrew Bible emerged; explore the narratives' eternal themes, such as creation and destruction, rivalry and loyalty, love and betrayal, doubt and faith, freedom and captivity, and forgiveness and revenge; and delve into the teachings that have served as a foundation for ethical and legal thought for thousands of years. *Open to 9th and 10th graders. Offered: fall term.*

REL255: THE NEW TESTAMENT

The New Testament is a sacred text for more than 2 billion people in the world. In this course, students will seek to understand some of its complexities and enduring significance in the lives of individuals, communities and societies. They will read much of the New Testament; study the life of Jesus, the travels and letters of Paul, and the book of Revelation; and consider these both in their historical context and in contemporary literature and films. Major themes include love and justice, power and liberation under Roman imperial rule, the formation of an authoritative canon of Christian texts, and an introduction to various approaches to scriptural interpretation. *Open to 9th and 10th graders. Offered: winter and spring terms.*

REL260: ONE NATION UNDER GOD?: RELIGIOUS TRADITIONS IN AMERICA

The United States has always encompassed a wide variety of various peoples and faiths. This course examines the religious traditions that make up American religious and cultural landscapes, focusing on Judaism, Christianity, Islam, Buddhism, Hinduism, etc. The distinctive ethos and practices of each are explored, along with their presence in the daily news. To assist students in experiencing and examining these religious traditions, the course will make use of

visual materials, guest speakers, and firsthand experiences such as elements of Buddhist meditation, a Passover Seder or a Muslim call to prayer. By fostering religious literacy, this course is designed to help students of all backgrounds develop skills for living in richly diverse communities. *Open to 9th and 10th graders.*

REL265: RELIGION AND POPULAR CULTURE

Images, ideas, stereotypes and symbol systems of religion surround us in popular culture, whether in movies, television shows, sports, fashion, the internet, music or literature. From Disney and *Black Panther* to TikTok and Instagram, the materials for this course will be drawn from a wide range of media, cultural artifacts and scholarship. Through the lens of American popular culture, this course introduces students to the academic study of religion by exploring religious traditions and topics such as the problem of evil, the afterlife, myth and the nature of the sacred. The course will conclude by inviting students to explore an expression of religion and popular culture that deeply interests them. *Open to 9th and 10th graders.*

REL270: FAITH AND DOUBT

Through fiction and personal narrative, this course invites students to explore the depth and complexity of religious experience in its many forms, from traditional belief through skepticism. The texts we will read range from some classics in this field to contemporary cultural selections. We will explore the timeless questions of the human condition, such as self-discovery, suffering, mortality, goodness, the quest for meaning and the development of a spiritual self. At the end of the term, students will have the opportunity to expound on these themes in their own lives as they create a mini-meditation, spiritual autobiography or culminating self-reflective project. *Open to 9th and 10th graders.*

REL290: SELECTED TOPICS IN RELIGION

This course is offered at student or departmental initiative. *Open to 9th and 10th graders.*

REL350: ISLAM

What is Islam? A religion practiced by over one billion people, Islam has adherents across the world from Mecca to Brooklyn. Through readings in history, scripture, theology, law and spirituality, as well as more contemporary memoir and artistic works, this course explores the diverse beliefs, practices and cultures of people who identify as Muslims. Students will examine the history of the early Muslim community and the life of the Prophet Muhammad, how Muslims relate to and revere the Prophet, the process of revelation and the compilation of the Quran, as well as the role that it plays in the devotional life of Muslims, the development of Islamic law (*Shariah*), arguments regarding the nature of God, and the ways that Islam is practiced in different cultures. Over the term, students will situate the study of Islam in conversation with topics such as women and gender in Islam, political Islam (Islamism), and Islam in the United States, including immigration, conversion and Black experiences of Islam. *Open to 9th, 10th and 11th graders. Offered: spring term.*

REL355: JUDAISM

What is Judaism? Contemporary Jewish communities forge unique identities, religious practices and spiritual paths in religiously and culturally diverse ways. This course introduces Judaism in a variety of forms and explores some of the many questions, challenges and affirmations of the many facets of Jewish identity, practices, core beliefs and ethics in the 21st century. For instance, Jews might practice yoga; sport tattoos; eat organic instead of kosher foods; grow up in an interfaith family celebrating Christmas and Hanukkah; become a rabbi; attend a Jewish LGBTQ wedding; identify as “spiritual” rather than “religious”; only attend synagogue during the Jewish high holidays; or voice doubts about Israeli politics. The class will explore these or other possibilities as a case study of how the Jewish people balance tradition and innovation to remain vibrant in a changing world. *Open to 9th, 10th and 11th graders. Offered: winter term.*

REL360: CHRISTIANITIES

What is Christianity? How has Christianity changed over time? Why are there so many different Christian groups (including Roman Catholic, Orthodox, Protestant and others)? How have Christian traditions shaped the politics of empire, nationalism and freedom struggles? This course explores these questions and others, with particular attention paid to different ways that Christian groups define themselves in relation to the wider culture, from the ancient world to today and from the Mediterranean through Asia, Africa, Europe, and South and North America. Students will have the opportunity over the term to study in more depth an area of interest. In addition to reading and discussion, the course will potentially include site visits, meetings with religious leaders and films. *Open to 9th, 10th and 11th graders. Offered: fall term.*

REL365: HINDUISM AND BUDDHISM

What is Hinduism? What is Buddhism? This course explores Sanatana Dharma — the duties, practices and traditions that define a Hindu way of life — as well as the traditions, beliefs and spiritual practices based on original teachings attributed to Siddhartha Gautama, the Buddha. As students explore these traditions, they will encounter concepts of ultimate reality, the (non)self and the purpose of human life that have informed diverse ethical systems and cultures in India, China, Tibet, Korea, Japan and Southeast Asia. Historical and philosophical studies of prominent stories, such as the Bhagavad Gita and the Jataka Tales, will provide students spaces to reflect on their own senses of what it means to live a devoted life. Students will also explore certain ways these religious traditions appear — through ideas, symbols and practices — throughout history and across the world, as they wonder about contemporary cultural representations of yoga and meditation in a global context. *Open to 9th, 10th and 11th graders. Offered: winter term.*

REL450: SOCIAL ETHICS: VALUES IN A CHANGING AMERICA

Whether you read the paper, scroll Instagram or follow trends on TikTok, you will see people disagreeing about how to resolve

some of society's conflicts. In this course, students examine various contemporary social issues such as pornography, reproductive rights, trans rights, immigration, the death penalty, artificial intelligence, privacy rights, political extremism, drug legalization and climate change, among other potential topics. Through engagement with current events and contemporary public conversations, the course provides students with ethical frameworks, conceptual tools and contextualized understanding necessary to evaluate and respond to the social issues of an ever-changing world. *Open to 11th and 12th graders.*

REL455: GLOBAL ETHICS: WHAT'S WRONG WITH THE WORLD?

Imperialism, wars, genocide, refugee crises, economic disparities, economic exploitation, propaganda, natural disasters and global warming — what kind of world do we live in? What kind of world ought we live in? These are the basic questions of global ethics. With consideration for a range of ethical theories, students study current global events in order to better understand why the world is the way that it is and what can be done about it. The course includes readings across disciplines like anthropology, sociology, political theory, philosophy and the sciences, while making use of current news sources, investigative journalism, documentary and feature films, new media and other potential sources. The course includes a student project on a topic of the student's interest concerning the world as it is and might be — and what we can do to get there. *Open to 11th and 12th graders. Offered: fall and winter terms.*

REL460: THE ETHICS OF THE MARKETPLACE

Does a corporation have responsibility beyond itself? Should maximizing profit override ethical considerations? Who or what protects the public interest? This course brings these questions in the world of business and management in conversation with central ethical theories such as utilitarianism and deontology. Students debate moral aspects of institutional policies and practices, in regard to the environment, fair labor, executive compensation, globalization and international sweatshops, consumerism and its opponents, race and gender issues in the market, advertising, insider trading, whistle blowing, and the corporate responsibilities of multinational firms. *Open to 11th and 12th graders.*

REL470: READING THE BIBLE AS LITERATURE

The Bible is a collection of books that has captured people's imaginations for thousands of years. From love poetry to mythology, architectural guidelines to legal codes, pithy sayings that reveal profound truths to apocalyptic stories that rival chilling science fiction, the Bible contains many genres and can provide a foundational background for the study of different subjects like literature, music, art and history. This course, designed both for those with little familiarity with the Abrahamic traditions (Christianity, Judaism and Islam) as well as those with significant interest in or knowledge of them, approaches the Bible as a literary text and invites students to think about how their own perspectives and backgrounds might impact their understanding of the text. In

addition to developing skills of close reading and interpretation, students will practice their own creative literary analysis through assignments such as theatrical retellings of biblical stories or writing textually contextualized fan fiction in order to deepen their knowledge of narratives and characters and their understanding of the larger themes that have made the Bible so influential in culture and media. *Open to 11th and 12th graders. Offered: fall term.*

REL480: SILICON VALLEY ETHICS: CASE STUDIES IN THE WORLD OF HIGH-TECH

In a world where technology permeates almost every aspect of our lives — the internet, smartphones, thousands of apps, cloud-based voice systems, artificial intelligence, robotics, the gig economy, video gaming, virtual reality, and numerous other products and applications currently under development — what ethical challenges are raised by their ubiquity? Through a series of case studies in an industry where a well-known motto is “move fast and break things,” this course will explore whether ethical considerations have kept pace with evolving technologies. Should social media be banned for children under a certain age? How have companies like Meta, Google, Amazon and OpenAI amassed so much power, and what harms have resulted? What might the “AI revolution” mean for the future of labor, education, law enforcement, warfare and even the planet itself? What are the implications of letting chatbots “think” with and for us? To assist students in developing skills for ethical deliberation and ethical reasoning regarding the challenges of emerging technologies and the corporations that own them, the course explores chapters from works such as Siva Vaidhyanathan's *Antisocial Media*, Ruha Benjamin's *Race After Technology*, Safiya Noble's *Algorithms of Oppression*, Cathy O'Neil's *Weapons of Math Destruction* and Karen Hao's *Empire of AI*. *Open to 11th and 12th graders. Offered: winter term.*

REL530: THOUGHT LAB: CURRENTS IN CONTEMPORARY PHILOSOPHY

All of us participate in creating culture, and all of us are affected by culture, for better or worse. Most of us have theories to explain why things are the way they are — and how things ought to be. Sociocultural theories seek to describe and interpret the social and cultural dynamics that shape lives in today's world. Over the term, students will discover and interrogate both scholarly and personal theories about the structures within which their lives take shape through a series of active learning “labs,” which explore cultural dynamics on Exeter's campus and in broader contexts (e.g., city, nation, online community). Each “lab” unites grounded investigation of cultural dynamics with readings drawn from landmark contemporary scholarship and each student's own ideation, facilitating students' practice of developing, articulating and testing theoretical outlooks. For instance, students might investigate a technology that is widely embraced in Exeter's student culture in conversation with Shoshana Zuboff's *The Age of Surveillance Capitalism*. Or they might engage theorists such as Jasbir Puar to examine current world events (e.g., the crisis in Gaza, the South and Central American refugee crisis) in terms of how the language of human rights and disability is being harnessed to control and debilitate a marginalized population. The course

culminates with a final project through which students identify and investigate a dynamic of their choice, with the goal of integrating and extending the knowledge gleaned from their time at Exeter.

Open to 11th and 12th graders. Offered: fall and spring terms.

REL535: POLITICS OF POSSIBILITIES: IMAGINATION, PLAY AND ALTERNATIVE FUTURES

The future can feel so uncertain even as it places clear expectations on us. What will my future hold? How should I prepare for life in college and beyond? To quote Ruha Benjamin, what thought partners will help us “imagine and craft the world [we] cannot live without, just as [we] dismantle the ones [we] cannot live within”? How does the play of imagination create or foreclose possibilities for the future? How can we work together to be the change that we want to see? These questions can feel even more complicated when confronting realities such as artificial intelligence, climate change, persistent racism, and social changes coupled with evolving technologies. When we consider that our visions of the future often reflect those of policymakers and popular culture, these questions become even more pressing. This course offers students the opportunity to imagine personal and global futures of flourishing and liberation within the realities of today’s world. Drawing upon disciplines that rethink future possibilities such as literature, creativity studies and political science, students will craft their own visions for the future in conversation with scholars and writers such as Ruha Benjamin, Octavia Butler, Saidiya Hartman and Mariame Kaba. Throughout the term, students will engage in hands-on projects to ground their learning. For instance, heeding Emma Goldman’s call to dance in the revolution, students are invited to experiment with how play might open futures worth fighting for. The course culminates in a collaborative final project that invites students to envision their desired future by articulating practical steps that can be taken today to move us all toward “the world we cannot live without.” *Open to 11th and 12th graders. Offered: fall and winter terms.*

REL540: HAPPINESS, FANĀ, EUDAEMONIA, NIRVANA

Happiness has always been at the heart of human inquiry. What will make me happy? How should I live? Who shall I become? Drawing from psychology, ritual studies and wisdom traditions — from Aristotle’s interest in eudaemonia through Sufi notions of fanā to various sources in the study of happiness in contemporary psychology — this course introduces students to different conceptions of happiness and paths to achieving it. The course invites students to explore the role of happiness in living a good life, cultural and societal influences on their own sense of self, and the effects of daily life rhythms and habits on personal well-being. Weaving together meaningful readings, reflective writing and activities, students will gain skills enabling them to develop a resilient understanding of happiness, along with language and practices to promote it, in their own lives today and as they prepare for life beyond Exeter. *Open to 11th and 12th graders. Offered: winter and spring terms.*

REL545: CRITICIZING RELIGION

Is there a destructive side to religion? Religion and religions have undoubtedly shaped the lives of individuals and communities around

the globe for millennia for the better, but would the world be a better place if we imagined, with John Lennon, a world with no religion? Contemporary examples of the destructive side of religion fill the news on a daily basis. On the other hand, religions around the world have been a driving force for peace, for justice, for compassion, for leading a purposeful life. Many people turn to religion to find resources that provide them with community, values and meaning in their lives. Is religion’s checkered past and present leading to increased secularism? Will science ultimately replace religion? The course will explore scientific, economic, political, feminist and queer critiques of religion — and their responses — from thinkers such as Friedrich Nietzsche, Karl Marx, Sigmund Freud, Ayn Rand, Mary Daly, Anthony Pinn, Ursula LeGuin, A.C. Grayling and “new atheists” like Richard Dawkins or Christopher Hitchens, as well as possible films. *Open to 11th and 12th graders. Offered: winter term.*

REL555: INTRODUCTION TO PHILOSOPHY

What is really real? How do I know what I know? Do I have free will? What is the good? These and other speculative questions have troubled the Western mind for millennia. This course follows a topical approach to the history of Western philosophy and focuses on such issues as metaphysics, epistemology, the problem of evil, the existence of God and the philosophical roots of ethics. Students will read from the works of ancient and modern writers such as Plato, Aristotle, Aquinas, Kant, Hume, Bentham, Locke, Arendt and Hill Collins to assist them in coming to their own understanding of these topics. Students will discover what philosophy is and how philosophers question and reason. *Open to 11th and 12th graders.*

REL560: EXISTENTIALISM

What is the meaning of life? Does life have any meaning? What does it mean to be human? Is God dead, or how do we live in a world where it appears God is absent? Focusing primarily on the 19th- and 20th-century literature of that group of writers called the existentialists, this course explores philosophical issues associated with the questions of existence and meaning in today’s world. Reading authors such as Beauvoir, Du Bois, Kierkegaard and Dostoyevsky, as well as Kafka, Sartre, Beckett and Camus, students compare traditional understandings of humanity and the world with other views that challenge, confirm or translate these concepts into terms relevant to the contemporary world. *Open to 11th and 12th graders.*

REL565: MYSTICISM AND THE CONTEMPLATIVE TRADITIONS

How does it feel to commune with “the Infinite,” and how does one do it? What are the horizons of personal and communal transformations? What is the self, and what does it mean to know? How do we think and speak about such topics as imagination, illumination, inspiration and synchronicity? These are some of the great “mystical and contemplative” questions. It has been said that all religions converge in the contemplative tradition — the great world illuminated by the swamis and yogis of Hinduism, the *bodhisattvas* and monastics of Buddhism, the Kabbalist teachers of Judaism, the Sufis of Islam and the Christian mystics, among

others. What can we learn by reflecting on their teachings and their practices? How might these traditions converse with current research on the mind-body connection, quantum physics, the multiverse, artificial intelligence and other emerging topics? To consider these questions and more, we will explore selections from a range of traditions such as the Upanishads of Hinduism, the Sufi poetry of Rumi, the songs and images of the Christian mystic Hildegard of Bingen, and Zen *koans*, among others. *Open to 11th and 12th graders. Offered: spring term.*

REL570: THE HOLOCAUST: THE HUMAN CAPACITY FOR GOOD AND EVIL

How did the Holocaust happen, and why do genocides still occur? How can some people commit such heinous crimes, while others remain bystanders, and still others risk their lives to save innocent people? We will consider these questions and many more as we examine the Holocaust from the perspective of the human capacity for good and evil. Discussions of human psychology and behavior, and the religious and historical sources of anti-Semitism, will be examined as background to the events of the 1930s and 1940s. We will also consider survivor testimony and the contributions of Holocaust survivors to international law regarding genocide, war crimes and crimes against humanity; enduring ethical questions of forgiveness, justice and reparations for grave, irreparable harm; and contemporary efforts to memorialize, represent and prevent mass atrocities, as well as to combat fascism and anti-Semitism in today's world. The course may include a project of each student's own design. *Open to 11th and 12th graders. Offered: fall and winter terms.*

REL575: EAST ASIAN WAYS OF KNOWING: ZEN BUDDHISM

Zen Buddhism offers rich and varied practices of knowing and living. Through reading primary sources, both ancient and modern, and engagement with a range of Zen practices, students in this course gain an appreciation for the religious tradition and its history, as well as the types of knowing that the tradition engenders. Students will contextualize Zen Buddhism in conversation with other East Asian religious and philosophical traditions, and they will read selections from classic Zen texts such as *The Ten Verses on Oxherding*, a step-by-step manual for attaining enlightenment, the *Lotus Sutra* and the *Heart Sutra*, and collections of *koans* (Zen training riddles), among other sources. Students will also explore other manifestations of Zen Buddhism across cultures and times, including contemporary media. *Open to 11th and 12th graders. Offered: winter term.*

REL580: AN INTERDISCIPLINARY APPROACH TO EPISTEMOLOGY

Epistemology is a philosophical term meaning “the study of knowledge.” This course explores how we know what we know about the world around us and within us. Questions engaged over the term include: What is knowledge? What differentiates and connects scientific, literary, philosophical and artistic ways of knowing? What makes someone good at “knowing”? For that matter, what does it mean to be a student? The class explores how

different modes of inquiry and experience can be distinguished from each other and then integrated into our understanding of knowledge. Class materials include readings from the Western philosophical tradition of reason (Plato, Descartes and Kant), the scientific revolution (Galileo, Newton and Einstein), postmodernism (Illich and Abram) and literature (Dostoyevsky and Woolf). Students will also experience the visual and performing arts, take a night trip to the observatory, and engage in contemplative or meditative traditions, including practices known as “mindfulness” or “mind-body work” (Zen Roshi Jan Chozen Bays). This interdisciplinary class is jointly taught by a member of the Religion, Ethics and Philosophy Department and a member of the Science Department. *Open to 11th and 12th graders. Offered: winter term.*

REL590: SELECTED TOPICS IN RELIGION, ETHICS AND PHILOSOPHY

This course is offered at student or departmental initiative and may change from year to year.

Science

The Science Department's primary mission is to provide for all students a foundation of excellence in the study of science. Whether as scientists or as scientifically literate citizens, Exonians must be well-prepared to enter a world of increasing social and technological complexity. In order to assist students in reaching this goal, the science curriculum is designed to offer students a variety of opportunities to engage with the world around them — in the classroom, in the laboratory and in field work.

Hands-on learning, both collaborative and individual, is at the heart of our course of instruction. The department considers the laboratory and the field to be its Harkness table, and students will have extensive practical experience. Therefore, classrooms in the Phelps Science Center and in the Grainger Observatory include both laboratory and discussion space. The department has integrated technology into the curriculum in a variety of guises, all designed to place the tools for discovery directly into the hands of the students.

The Science Department believes that successful scientific inquiry requires the integration of observational ability, quantitative skills and analytical thinking; in all courses, students will be challenged to reason creatively and to think critically.

In keeping with the program broadly outlined above, the Phillips Exeter Academy Science Department strongly encourages students to take all three basic courses — biology, chemistry and physics — as a minimal preparation for college.

■ Biology

LABORATORY POLICY FOR BIOLOGY

Laboratory work is an essential and integral part of the biology curriculum in the Science Department. The proximity to local ponds, rivers and the coast allows students to collect and observe representative organisms from those habitats for observation in the laboratory. Behavior, feeding strategies and structural modifications as they apply to function are studied in these organisms. In addition, observation of preserved specimens and observation of dissection is required of those enrolled in biology courses at the Academy.

BIO210/220/230: AN INTRODUCTION TO BIOLOGY

This sequence of courses is offered fall (BIO210), winter (BIO220) and spring (BIO230). The sequence begins with an exploration of the scientific process. Biomolecules are studied as a basis for the understanding of cell structure and cell processes, including the role of DNA and protein synthesis. Classical genetics is introduced, leading to a study of human anatomy and physiology. Finally, the study of evolution is followed by a survey of the various kingdoms of

living organisms studied through the lens of ecology. Development of laboratory skills and scientific thinking are emphasized throughout the courses. *Open to 9th graders (10th graders with departmental permission). Meets during the reserve format.*

BIO310/320/330: PRINCIPLES OF BIOLOGY

This sequence of courses is offered fall (BIO310), winter (BIO320) and spring (BIO330). This yearlong survey follows a similar sequence of topics as BIO210/220/230 but uses a different textbook and goes into greater depth. Human anatomy and physiology are explored with a required vertebrate dissection; students who choose not to dissect will engage in replacement lab activities and need to apply to the department for this exception. Not open to students who have completed the BIO210/220/230 sequence. *Open to 10th, 11th and 12th graders. Meets during the reserve format.*

BIO440: REGENERATIVE AGRICULTURE

This course will explore agricultural practices that aim to have positive environmental impacts, such as improving soil health, increasing native species diversity and sequestering carbon. It will also explore agricultural practices that aim to have positive social impacts, such as reducing food insecurity, honoring ancestral farming practices and promoting economic wellbeing of local communities. Scientific topics such as conventional versus organic systems, seed banks, closed loop food production, permaculture, soil science, nitrogen cycles and plant physiology will be investigated. Emphasis will be placed on experiential learning on local farms and campus. The course includes a service learning component and potential for research projects. *Prerequisite: one year of introductory biology. Open to 11th and 12th graders (10th graders with departmental permission). This course meets during a reserve format in order to create a double-format meeting time for weekly labs. Offered: spring term.*

BIO450: HUMAN PHYSIOLOGY

Biology 450 examines how the human body functions. The complexity of and interactions between different systems will be explored. Extensive laboratory investigations, including a mammalian dissection, computer applications and project work, compose a significant part of the course. *Prerequisite: one year of introductory biology. Open to 11th and 12th graders (10th graders with departmental permission). This course meets during a reserve format in order to create a double-format meeting time for weekly labs. Offered: winter term.*

BIO455: ANIMAL BEHAVIOR

This course is an introduction to the study of animal behavior. It explores the development, cause, evolutionary origin and function of a host of behaviors, such as sexual behavior, communication,

dominance, navigation and cognition. Weekly laboratory work and field trips involve the observation of and experimentation with live animals, such as fish, crayfish, frogs, birds, dogs, farm animals and honeybees. Students will track, camera trap and collect sound recordings of our local animals as part of a long-term study of the Academy's meadows and forests. The course includes multiple opportunities for experimental design. *Prerequisite: open to 11th and 12th graders (10th graders with departmental permission) who have taken one year of introductory biology. This course meets during a reserve format in order to create a double-format meeting time for weekly labs/field trips. Offered: spring term.*

BIO460: ORNITHOLOGY

This course emphasizes field identification of locally common species and habitats. Spring migrants are the focus of the course, along with winter finches and waterfowl that may have lingered in the Exeter area. The course utilizes a systems approach to the biology of birds, with investigations into their life histories, ecology, evolution and behavior. *Prerequisite: one year of introductory biology. Open to 11th and 12th graders (10th graders with departmental permission). This course meets during a reserve format in order to create a double-format meeting time for weekly labs. Offered: spring term.*

BIO465: ECOLOGY

This is a place-based, community ecology course which focuses on our central New England region and covers many of the major principles of ecology. It also includes learning how to identify our common forest trees, understory plants and game animals, as well as learning to look for evidence to determine the disturbance history of our current forested lands. It involves weekly field trips to ecosystems like a nearby kettle bog, Plum Island's Parker River National Wildlife Refuge and our local central New England forests. The reading list can include Wessel's *Reading the Forested Landscape* and *The Myth of Progress*, Leopold's *A Sand County Almanac* and Peterson's *Eastern Trees*. *Prerequisite: one year of introductory biology. Open to 11th and 12th graders (10th graders with departmental permission). This course meets during a reserve format in order to create a double-format meeting time for weekly labs. Offered: fall term.*

BIO470: HUMAN POPULATIONS AND RESOURCE CONSUMPTION: IMPLICATIONS FOR SUSTAINABILITY

In this course students consider human impact on the environment. Issues of human population, demography and carrying capacity will be explored in relationship to the world's food resources and urban land use and management. Some of the consequences of the most basic decisions we make as humans — how many babies should we have, what do we eat, and where do we live? — will be considered. The legal, ethical, economic and political aspects of these topics will be an integral part of the course. Lab work, as well as the completion of a local service-learning project, will be required. *Prerequisite: one year of introductory biology. Open to 11th and 12th graders (10th graders with departmental permission). This course meets during a reserve format in order to create a double-format meeting time for weekly labs. Offered: winter term.*

BIO475: EVOLUTION

Evolutionary biologist Theodosius Dobzhansky wrote in 1973 that "Nothing in biology makes sense except in the light of evolution," and his statement still holds true today. Students in this course will read Jonathan Weiner's Pulitzer Prize-winning book *The Beak of the Finch*, which documents an ongoing study of evolution in Darwin's finches on the Galapagos Islands. They will also read selected chapters from Sean Carroll's text on the burgeoning field of Evolutionary Developmental Biology (Evo Devo), *Endless Forms Most Beautiful*. We will also consider Darwinian fitness in human populations. Labs will include an investigation of avian comparative anatomy and a study of students' own mitochondrial DNA using molecular techniques such as PCR and gel electrophoresis. *Prerequisite: one year of introductory biology. Open to 11th and 12th graders. Meets during the reserve format. Offered: winter term.*

BIO480: BIOCHEMISTRY AND HUMAN NUTRITION

This course explores the chemistry, digestion and functions of carbohydrates, proteins, fats, water, vitamins and minerals in the human body. The importance of adequate personal nutrition for optimal performance as an adolescent is stressed. Special considerations include world hunger, sports nutrition, eating disorders, drug-nutrient interactions, weight control, and the relationship between nutrition and disease. Students will apply the scientific method and develop skills in personal diet selection, consumerism and in evaluating controversial nutrition issues in the literature. Laboratory investigations will focus on the biological chemistry of foods. As a full term project, students will record and analyze one week of their diet for adequate levels of all nutrients. *Prerequisite: one year of introductory biology or one year of introductory chemistry. Open to 11th and 12th graders (10th graders with departmental permission). Meets during the reserve format. Offered: fall term.*

BIO485: MARINE BIOLOGY

The relationships and interactions between marine organisms and their environment are studied in class and in the field. Field trips to estuarine and rocky intertidal habitats allow students to become familiar with organisms and to employ techniques often used by marine biologists. *Prerequisite: one year of introductory biology. Open to 11th and 12th graders (10th graders with departmental permission). This course meets during a reserve format in order to create a double-format meeting time for weekly labs. Offered: fall and spring terms.*

BIO486: INTRODUCTORY GENETICS I

This course considers the classical and contemporary views of the nature, transmission and function of the hereditary material. Laboratory investigations in plant and animal genetics supplement class discussion. *Prerequisite: one year of introductory biology. Open to 11th and 12th graders (10th graders with departmental permission). Meets during the reserve format. Offered: fall term.*

BIO490: COLLABORATIVE RESEARCH

Collaborative Research is a team-based research course designed with the purpose of helping students develop their understanding of scientific investigation. The team-based approach allows for students from a variety of scientific backgrounds to contribute to a robust research project under the umbrella of biochemistry and biology, as the entire class will be working on one project. Both within the framework of this project and through additional readings and activities, such as statistical analysis and presentations of their work, students will develop their understanding of experimental design and research methods. Students will conduct research outside of class time as needed. No previous research experience is required, as this course seeks to cultivate scientific thinking in all students. Possible projects include the design and construction of plant-based bioreactors to study recombinant proteins for bioremediation or the effects of ocean/river rising pH levels on fish enzymes. Research projects can change annually dependent on the interests of the students and faculty involved and, for practical reasons, will be finalized before the course begins. *Prerequisites: one year of introductory biology and one year of introductory chemistry. Students must complete an application to be considered for the course. This course meets during a reserve format in order to create a double-format meeting time for weekly labs. Not offered in 2026-27.*

BIO510/520/530: ADVANCED BIOLOGY

This sequence of courses is offered fall (BIO510), winter (BIO520) and spring (BIO530). Together, these three courses are equivalent to an introductory college course. Collectively, they cover principles of biological chemistry, cytology, cellular energy transformations, molecular genetics, heredity, evolution, taxonomy, systematics, ecology and population dynamics. Independent laboratory work is an integral part of the course. After completing this three-term sequence, students will be prepared to write the Advanced Placement examination in biology. *Prerequisite: one year of high-school biology and one year of high-school chemistry. Open to 11th and 12th graders. Meets during the reserve format.*

BIO586: MOLECULAR GENETICS

This course examines the biochemistry of the gene in greater detail and considers the underlying principles of recombinant DNA technology. Because DNA science is experimental, much of the time available in this course will be devoted to laboratory work learning techniques of DNA isolation, analysis and manipulation. *Prerequisite: BIO486 or BIO510. Open to 11th and 12th graders. Meets during the reserve format. Offered: winter term.*

BIO588: THE GENETIC BASIS OF CANCER

Cancer arises when normal cell growth becomes uncontrolled, bypassing the body's checkpoints and resulting in the proliferation of abnormal tumor cells that spread throughout the body. Our efforts to understand cancer date back thousands of years, making it an extremely well-studied condition that spans many fields within biology and medicine. This course offers an in-depth study of cancer from the perspective of genetics, highlighting the roles

of oncogenes, tumor suppressors, mutation and chromosomal instability. Students will build a foundational understanding of the cell cycle and its checkpoints. They will investigate the role of environmental factors and everyday cellular processes in driving carcinogenesis, seeking to understand how our bodies deploy an array of DNA repair mechanisms to prevent cancer development. The class will finish with an exploration of gene therapy and personalized medicine. Choose this course if you are excited to dive deep into human genetics, be exposed to the newest techniques used in cancer biology, learn the skills needed to access primary literature, or want to meet experts in the field of cancer research. *Prerequisite: BIO486 or BIO510. Open to 11th and 12th graders. Meets during the reserve format. Offered: spring term.*

BIO650: MALARIA: EXPLORING BIOINFORMATICS AND NEXT-GENERATION SEQUENCING

In 2020 there were about 241 million cases of malaria worldwide and 627,000 deaths. About 90% of malaria cases and 94% of malaria deaths occur in sub-Saharan Africa. About 80% of the deaths are children under 5. Malaria was once endemic in the United States, but it was declared eradicated in 1951. There are mosquito species in North America that can host and transmit the parasite that causes malaria, and therefore there is a risk, due to climate change and globalization, that malaria could become endemic in North America again. Researchers around the world are working to understand malaria with the goal of effective treatment and eradication. One hypothesis is that there may be genetic differences between individual mosquitoes that affect their ability to act as vectors. In partnerships with Catteruccia Lab at Harvard T.H. Chan School of Public Health, students will work to generate a genome sequence for a laboratory strain of mosquito used in malaria research. To do this, students will learn basic bioinformatics skills and perform the wet lab steps from isolating the DNA to submitting the sample for sequencing. The class will discuss the background of malaria, current research and potential future global malaria goals to place the project in a broader context. *Prerequisite: BIO486 or BIO510. Open to 11th and 12th graders. Students must complete an application for this course. This course will include two required labs on Sundays, each four to six hours long (specific dates to be announced in the application process). These graded labs are critical to the success of the course, so students must commit to attending both of these labs in their entirety before accepting a spot in the course. Students cannot be co-enrolled in BIO650 and BIO670. This course meets during a reserve format in order to create a double-format meeting time for weekly labs. Offered: spring term.*

BIO670: BIOLOGY RESEARCH

Students in this course will be exposed to the process of scientific investigation through collaboration with researchers at Stanford University. The overarching goal of Dr. Kim's lab at Stanford is to explore the function and development of insulin-producing cells in humans with the ultimate goal of curing type I and type II diabetes. The fruit fly is used as a model system because it has insulin-producing cells and many of the regulatory pathways are the same as in humans. A critical part of this work, as in all experiments

involving fruit flies, is to be able to control gene expression as specifically as possible. Students will be involved in finding regions of DNA that control gene expression in fruit flies. To do this they will learn current techniques in fly biology, fluorescence microscopy, molecular biology and bioinformatics. Useful strains of flies made and characterized by students will be used by researchers in Dr. Kim's lab and made available to all scientists working on fruit flies. *Prerequisite: BIO486 or BIO510. Open to 11th and 12th graders. Students must complete an application for this course. This course will include regular required lab work outside of class time, typically in the mornings, evenings and/or weekends. This graded lab work is critical to the success of the course, so students should consider this requirement carefully before applying. Students cannot be co-enrolled in BIO650 and BIO670. Meets during the reserve format. Offered: spring term.*

■ Chemistry

CHE310/320/330: PRINCIPLES OF CHEMISTRY

This sequence of courses is offered fall (CHE310), winter (CHE320) and spring (CHE330). An introduction to the theoretical framework of modern chemistry, this laboratory-based course is designed to foster scientific thinking, problem-solving skills and cooperative learning. Topics include atomic and molecular structure, stoichiometry, states of matter, chemical and physical behavior of elements and compounds, solution chemistry, kinetics, equilibrium, thermochemistry and electrochemistry. *Mathematics co-requisite: For CHE310, students must be concurrently enrolled in MAT220 or MAT22T, or higher. Open to 10th, 11th and 12th graders. Meets during the reserve format.*

CHE411/421/431: ACCELERATED CHEMISTRY

This sequence of courses is offered fall (CHE411), winter (CHE421) and spring (CHE431). This course is designed for those students who have not had a previous full-year, laboratory-based chemistry course, but who would like to enroll in an accelerated one-year course that covers most of the topics on the Advanced Placement exam. Because this course covers two years of chemistry in three terms, students should expect that this course will progress at a more rapid pace and demand a greater degree of independent study than the typical one-year science course. Students wishing to enroll in Chemistry 411 are expected to demonstrate a high level of proficiency in both mathematics and physics. After registering for this course, students must go through an application process. The Science Department will review applications and select those who are qualified for enrollment. *Prerequisite: a full-year laboratory physics course. Open to 10th, 11th and 12th graders. Meets during the reserve format.*

CHE450: CHEMISTRY OF THE ENVIRONMENT

This advanced course investigates the chemical principles that underlie current environmental issues. Students will study the chemistry of the natural environment (atmosphere, soil and water) and develop skills necessary to analyze alterations that human beings have made. Specific topics include ozone layer depletion,

acid rain, the greenhouse effect, photochemical smog, toxic organic pollutants and heavy-metal contamination. Laboratory work will include field sampling and will emphasize the methods required to make accurate measurements of both background and elevated levels of chemical substances in the environment. *Prerequisite: one year of introductory chemistry. Open to 11th and 12th graders. This course meets during a reserve format in order to create a double-format meeting time for weekly labs. Offered: spring term.*

CHE460: ORGANIC CHEMISTRY

Organic chemistry has been called “the basis of life” and is responsible for countless natural phenomena — the color of a flower, snake venom and the antibacterial properties of penicillin. In this course, students will explore the structure and reactivity of these compounds. Organic chemists are also molecular architects and have built on nature's designs to create everything from new medicines to revolutionary materials such as plastics. Therefore, laboratory investigations include the synthesis and purification of common organic materials such as wintergreen oil, aspirin, rubber, fragrant esters and other polymers. There will be particular emphasis on the intersection of chemistry, society and sustainability. *Prerequisite: one year of introductory chemistry. Students who have completed one year of advanced or accelerated chemistry may also take this course. Open to 11th and 12th graders. Meets during the reserve format. Offered: fall term.*

CHE470: BIOCHEMISTRY OF MEDICINAL DRUGS

Medicinal chemistry provides a bridge from the periodic table to the array of natural and synthesized biologically active agents available today. The ongoing development of medicinal drugs aims to integrate new scientific discoveries with precision-based strategies for treating individuals as well as large populations. A key goal in the design of new drugs for the pharmaceutical industry is to treat symptoms without the harm of side effects. Moreover, the scale-up and production of medicines are dependent on public health investment, while social and economic factors underpin access. This course will take a deeper look at the major classes of pharmaceutical drugs, including hypertension, high cholesterol, oncology, depression, diabetes, asthma and vaccines. How companies currently distribute drugs, determine pricing and ensure equity of access will be examined. Widely used compounds such as nicotine, nonsteroidal anti-inflammatory agents, contraceptives, cannabinoids and pain suppressors will be explored based on their chemical structure and its relationship to function. Lab activities will provide experience with computational drug design, controlled-release drug delivery systems, pharmacokinetics and nuclear medicine. *Prerequisite: one year of chemistry and one year of biology. Open to 11th and 12th graders (10th graders with departmental permission). Meets during the reserve format. Offered: winter term.*

CHE510/520/530: ADVANCED CHEMISTRY

This sequence of courses is offered fall (CHE510), winter (CHE520) and spring (CHE530) and is the equivalent of an introductory college course. Advanced Chemistry begins with a review of

fundamental chemical principles and reactivity before investigating thermochemistry, atomic structure, bonding, states of matter, equilibria, kinetics and electrochemistry. Because Advanced Chemistry is an experimental science, laboratory inquiry and analysis are integral parts of this course. This three-term sequence covers most of the topics on the Advanced Placement examination in chemistry. *Prerequisite: one year of introductory chemistry. Open to 11th and 12th graders. Meets during the reserve format.*

■ Earth and Planetary Science

EPS450: EARTH AND THE CLIMATE CRISIS

This course explores (1) the dynamic and complex interconnected systems of our planet and (2) the current global climate crisis. In the first part of the course, students survey the basic workings of planet Earth, from plate tectonics, the rock cycle, geologic time, mountain formation, and natural hazards such as earthquakes and volcanoes. The second part of the course is devoted to the study of Earth's climate system and the current global climate crisis. Students will study Earth's energy budget and the effects of various natural and anthropogenic factors that control the climate, such as solar radiation, greenhouse gases, aerosols, ocean circulation, Milankovitch cycles, El Niño events and volcanic eruptions. The study of positive and negative feedback loops helps students understand past climates and predict future climates. Students use global computer models to predict the effects of increasing atmospheric CO₂ to surface air temperature, ice cover, global albedo, precipitation, etc. These models help students quantitatively assess the effects of natural and anthropogenic causes on the current climate crisis. A final project focuses on our ever-growing energy needs in the context of the global climate crisis. Local field trips complement classroom discussion. *Prerequisite: one year of physics or chemistry. Open to 11th and 12th graders. This course meets during a reserve format in order to create a double-format meeting time for field trips. Offered: fall term*

EPS460: OCEANOGRAPHY: THE OCEAN ENVIRONMENT AND A CHANGING CLIMATE

This course will explore major physical and chemical oceanographic processes and their influence on climate change. Topics will include ocean circulation, dissolved chemicals and nutrients, and tides and waves. Students will become familiar with terms such as the Coriolis Effect, gyres and eddies, the Gulf Stream, thermohaline circulation, lysocline and carbon compensation depth, El Niño Southern Oscillation, thermal expansion and isostatic crustal rebound. We will also examine the role of the ocean in climate regulation and sequestering carbon, sea level rise, beach erosion and hurricane formation. Day-to-day classes will include discussion, lab activities and data analysis. *Prerequisite: one year of introductory chemistry. Open to 11th and 12th graders (10th graders with departmental permission). Meets during the reserve format. Offered: winter term.*

■ Environmental Science

After completing all three courses, students will be prepared to write the Advanced Placement examination in Environmental Science. Courses can be taken in any sequence.

BIO465: ECOLOGY

BIO470: HUMAN POPULATIONS AND RESOURCE CONSUMPTION: IMPLICATIONS FOR SUSTAINABILITY

CHE450: CHEMISTRY OF THE ENVIRONMENT

■ Physics

PHY210/220/230: AN INTRODUCTION TO PHYSICS

This sequence of courses is offered fall (PHY210), winter (PHY220) and spring (PHY230). This course investigates the topics of Newtonian mechanics: motion, force, gravitation, energy and momentum conservation; and topics in the physics of optics, waves, electricity and magnetism. Students will use both qualitative and quantitative methods to develop understanding of these fundamental concepts. Laboratory activities are a major component of the course, which satisfies the physical science graduation requirement. This course assumes proficiency in basic algebraic skills. *Meets during the reserve format.*

PHY310/320/330: PRINCIPLES OF PHYSICS

This introductory physics course covers similar topics as PHY210/220/230, but does so at a quicker pace and with greater mathematical depth (see prerequisites). This sequence of courses is offered fall (PHY310), winter (PHY320) and spring (PHY330). *Prerequisite: successful completion of MAT230. New students will be placed appropriately by the Science Department. Open to 10th, 11th and 12th graders (9th graders with departmental permission). Students who have taken PHY210/220/230 may not take this sequence. Meets during the reserve format.*

PHY400: MODERN PHYSICS

In the early 20th century, two major scientific revolutions drastically altered our understanding of nature: quantum mechanics and Einstein's theories of special and general relativity. These will be the main themes of this course. Students will perform and analyze experiments to measure the speed of light; time dilation; the mass, charge, wave nature and spin of the electron; as well as the quantization of energy. In situations less conducive to hands-on work, data from historical experiments or computer simulations will be provided for analysis. This course picks up where a rigorous, yearlong introductory physics course leaves off. Proficiency in algebra and basic physics principles will be expected. *Prerequisite: one year of physics, which includes the study of motion, force, orbital motion, energy, gravitation, electricity, magnetism, waves and light. Open to 11th and 12th graders (10th graders with departmental permission). Meets during the reserve format. Offered: fall term.*

PHY440: APPLIED PHYSICS

How did diffraction of light help decipher the DNA structure? How can ultrasonic resonance treat kidney stones without an invasive operation? How can MRI see into living tissue? How do electron microscopy, solar panels or thermal imaging work? This course explores the physics principles that underlie biological, medical and energy technologies. Through laboratory experimentation, or with data from historical experiments, students will revisit certain topics they know from their first year of physics (e.g., diffraction, resonance), learn new ones (e.g., blackbody radiation, the photoelectric effect) and investigate their applications. As a capstone, students will present a poster of their special interest. *Prerequisites: one year of biology; one year of physics — which includes the study of motion, force, orbital motion, energy, gravitation, electricity, magnetism, waves and light. Open to 11th and 12th graders. Meets during the reserve format. Offered: spring term.*

PHY450: ROBOTICS

Students in this course will learn to use a microcomputer to control output devices and interpret input sensors. Students will complete a series of small projects that will culminate with a working autonomous robot. The initial focus of the course requires students to build and analyze several micro-controlled devices. Students will learn fundamental engineering skills such as programming the microcomputer and building simple electronic circuits. The middle portion of the course will feature the construction of an autonomous robot that uses a microcomputer and several sensors to make navigational decisions. The final weeks of the course will require students to independently research, design and implement a system or systems that will increase the capabilities of their robot. This is an introductory robotics course and is not connected to the PEA Robotics Club. *Prerequisite: one year of physics or departmental permission. Open to 11th and 12th graders. This course meets during a reserve format in order to create a double-format meeting time for weekly labs. Offered: spring term.*

PHY460: ELECTRONICS

This introduction to electronics is a hands-on, project-oriented course. Students will build a variety of simple devices, including timing circuits, alarms, flashers, amplifiers and counters. By designing, building and analyzing these circuits, students will gain a firsthand knowledge of a variety of basic electronic components, including resistors, capacitors, switches, relays, transformers, diodes, transistors and several integrated circuits. Students will use Arduinos throughout the course for analyzing and testing, and as a central piece of their circuit design. Though some experience in programming is helpful, it is not required for this course. *Prerequisite: one year of physics or departmental permission. Open to 11th and 12th graders. This course meets during a reserve format in order to create a double-format meeting time for weekly labs. Offered: winter term.*

PHY470: INTRODUCTORY ASTRONOMY

This introductory course emphasizes introductory observational aspects of astronomy. Topics include the relationship between the

Earth and the sky, short-term and long-term cycles in the celestial sphere, the exploration of the solar system, light, telescopes, and stellar evolution cycles. Practical work is done at Grainger Observatory, located on the Exeter campus. Students use a variety of telescopes at the Observatory to make their own observations and measurements. *Prerequisite: one year of physics or chemistry. Open to 11th and 12th graders (10th graders with departmental permission). Offered: fall, winter and spring terms.*

PHY480: SPECIAL TOPICS IN ASTRONOMY

This course examines selected topics of special interest in astronomy and astrophysics, including telescopes and electronic imaging equipment, multifrequency analysis of deep sky imagery, the study of open clusters, nebulae, and solar system objects. Students use the full range of equipment at Grainger Observatory, located on the Exeter campus, and pursue independent projects throughout the term. *Prerequisite: PHY470. Open to 11th and 12th graders (10th graders with departmental permission). Offered: winter term.*

PHY510/520/530: ADVANCED PHYSICS

This sequence of courses is offered fall (PHY510), winter (PHY520) and spring (PHY530). This three-term sequence is taken as a second year of physics. In the first term, an emphasis is placed on synthesizing a variety of fundamental topics into a coherent whole. Topics include linear and rotational kinematics, dynamics including torque, energy conservation, linear and angular momentum conservation, and gravitation. Students will study a number of complex situations, performing in-depth laboratory experiments and calculus-based theoretical analysis. In the second term, students study electricity and magnetism, making extensive use of experimental results and of calculus. In the third term, students finish the study of magnetism, including Maxwell's equations. Finally, they study oscillatory phenomena, including both mechanical and electrical systems. After taking this three-term sequence, students will be able to take the Physics C Advanced Placement examinations in Mechanics and Electricity and Magnetism. *Prerequisite: open to 11th and 12th graders (10th graders with departmental permission). Eleventh and 12th graders must have one year of introductory physics and concurrent enrollment in MAT430/431 or higher (or concurrent enrollment in MAT420/421 with departmental permission, but permission will not be granted for a student who places into MAT420/421 by completing summer math work). Tenth graders must have one year of introductory physics, concurrent enrollment in MAT430/431 or higher, and departmental permission. Meets during the reserve format.*

PHY570: ADVANCED ASTRONOMY METHODS

This course emphasizes the practical and computational skills used to make precise measurements of astronomical phenomena with the goal of understanding the scale of the universe. Topics include: the interstellar medium, Cepheid variables, mapping the Milky Way, advanced stellar photometry and spectroscopy, and the cosmic distance ladder. Students work at Grainger Observatory, located on the Exeter campus, pursue independent projects throughout

the term, and study the work in progress at other observatories and research centers. *Prerequisite: PHY470. Open to 11th and 12th graders (10th graders with departmental permission). Offered: spring term.*

PHY640: QUANTUM MECHANICS

This course seeks to outline the mathematical underpinnings of the present theory of the microscopic world. We begin where PHY400 ends: the two-state system known as the qubit. With the qubit as our paradigm, we will investigate the mindset and mathematical machinery needed to describe quantum mechanical systems. Armed with new techniques, we will look at systems with more degrees of freedom and necessarily more complex mathematical structure. We will examine solutions to the Schrödinger equation and their interpretations as wavefunctions of probability. Study will include bound states of the particle-in-a-box, the harmonic oscillator and the hydrogen atom, as well as quantum-mechanical tunneling and reflection of free electrons. We will examine the description and

consequences of the electron's indistinguishability on the structure and stability of matter. The mathematics required is a familiarity with vectors, matrices, integral calculus, infinite series and elementary differential equations at the MAT520 level. *Prerequisites: PHY400, PHY520 and MAT520 or permission of the instructor. Meets during the reserve format. Offered: spring term.*

■ Selected Topics in Science

BIO/CHE/PHY590: SELECTED TOPICS IN SCIENCE

For advanced students of science, these courses feature topics that are beyond the scope of our regular course offerings. A 590 course will run when a specific topic is identified by interested students, a teacher agrees to teach the course, a sufficient number of students with the necessary prerequisites register for the course, and as staffing allows. Topics could fall within the confines of biology, chemistry or physics, or could be interdisciplinary within science.

Theater and Dance

Our department's mission is to inspire creativity and growth through the collaborative process. We aim to inspire students of all identities and backgrounds toward a greater understanding of themselves and the world through experiential and embodied learning, creative inquiry, research and ensemble development. Students also acquire a host of transferable skills, such as teamwork, confidence, problem-solving, creative thinking, empathy, and verbal and non-verbal communication.

All interested students, regardless of experience, are welcome. Dance strives to offer students of all levels and interests the opportunity to study, choreograph, perform and explore various dance forms. Theater provides opportunities for every student to explore, whether acting onstage or working behind the curtain with costumes, lighting, directing or more. We also offer courses related to film and public speaking.

The performing arts come together under the same roof in the David E. and Stacey L. Goel Center for Theater and Dance, which offers an array of inspiring spaces. Connection and collaboration flow between two dance studios, a fully equipped proscenium theater and actors' laboratory thrust-stage, a spacious rehearsal studio, classrooms, and costume and scene shops.

Unless otherwise stipulated, all courses are open to students at all grade levels and require no previous experience.

Theater

■ Theater Study

THR202: ACTING I

In this introductory course, students explore the many exciting roles that actors can play in performance making. Students develop techniques for bringing their own individual interests and gifts to building a dynamic and imaginative ensemble together. There are opportunities to investigate texts, experiment with character and practice improvisation. Through a synthesis of physical and vocal training, reading, writing, rehearsing and performance, students experience acting as a collaborative endeavor. *Provides one term of credit toward the studio/performance arts requirement. Offered: winter and spring terms.*

THR300: COSTUME DESIGN AND CONSTRUCTION

This is an explorative course focusing on finding your vision as a designer and learning to communicate your designs as an artist and craftsperson. In this course, students will dive into works from theater, dance, fashion design and visual art to develop their personal design style. Through discovery and creative freedom, students will create their own designs and gain tools to communicate their ideas through visual renderings, paintings and draping. In addition to design, students will learn sewing techniques, enabling them to make a basic garment to culminate the class. *Provides one term of credit toward the studio/performance arts requirement. Offered: fall term.*

THR404: ACTING II

This intermediate course focuses on developing and supporting each actor's unique approaches to performance making and ensemble-building. Vocal and physical training deepens techniques introduced in THR202, empowering students to explore a diverse selection of dramatic texts and develop skills in improvisation and devising. Students may work with "heightened" texts or improvisations that present new challenges in terms of language, physicality, characterization, style or content. Students rehearse, workshop and perform material for each other, becoming increasingly adept at communicating and synthesizing creative ideas. *Provides one term of credit toward the studio/performance arts requirement. Prerequisite: THR202 or permission of the department chair. Offered: winter term.*

THR502: ADVANCED ACTING ENSEMBLE

This course offers students the opportunity to build on performance skills acquired throughout their Exeter career and immerse themselves in a rigorous, thoughtful ensemble process. The class will conduct intensive analysis and rehearsal of either the work of a playwright or devise new performance material together based on the interest of the group. It may culminate in a series of fully explored scenes or in a full-length production. *Provides one term of credit toward the studio/performance arts requirement. Students may repeat this course for credit. Prerequisite: an earlier department acting course or permission of the department. Students must sign up for PEC109 or Choice Format. Offered: spring term.*

THR590: SPECIAL TOPICS IN TECHNICAL THEATER: LIGHTING DESIGN AND PRODUCTION

In the first part of this course, students will discuss the function and properties of stage lighting as well as the myriad of STEM components of the lighting design process. In the second part of the term, each student will utilize the principles learned to collaborate with a student choreographer to design lighting for their piece in the Dance Company Concert. *Provides one term of credit toward the studio/performance arts requirement. Offered: spring term.*

ENG512: PLAYWRITING

See English offerings.

■ Theater Production

The Theater and Dance Department produces at least one theater and one dance production each term. Students audition for parts in the production or interview for positions on the technical crew, and every effort is made to engage as many students as possible.

Note: A full credit toward the studio/performance arts requirements is awarded when a student has earned a total of one (or more) credits in theater and dance courses.

THRO20: THEATER AND DANCE TECH CREW

Tech crew is designed to provide students with skills and knowledge to work backstage on theatrical and dance productions as part of the stage crew. Through hands-on learning, students gain knowledge of theater technology, safety and design. Tech crew assists in the construction and painting of scenery, props, costume construction, makeup application, and the hanging and focus of lights. No experience is necessary, though a willingness to learn a variety of skills is expected. During performances, tech crew members are responsible for running lights and sound, stage managing, facilitating costume changes, and moving set pieces and props. Tech crew meets three to four times per week, as well as daily during performance week. Performances are Friday through Sunday at the end of each term, and students are expected to be a member of the stage crew. *All grade levels may participate; no previous experience required. Provides 1/3 credit toward the studio/performance arts requirement. Students enrolled in THRO20 must also be enrolled in PEC109 for PE credit.*

THRO30: NEW PLAYS ENSEMBLE

The New Plays Ensemble is a performance opportunity designed for students to explore contemporary plays and collaborative ensemble-building while deepening their acting abilities. There will be a focus on presenting new work by artists from communities that have been historically marginalized in traditional theater spaces. Rehearsals will culminate in a theatrical production onstage in the Goel Center, likely as a staged reading (with actors having scripts in hand). Show titles and audition dates are announced by the department, and students audition to be part of the ensemble. A passionate sense of exploration, play and commitment is the only requirement. *Provides 1/3 credit toward the studio/performance arts requirement. Students enrolled in THRO30 must also be enrolled in PEC109 for PE credit.*

THRO40: THEATER PERFORMANCE

Theater Performance offers students the opportunity to perform as part of a theatrical production onstage in the Goel Center. Show titles and audition dates are announced by the department, and students audition to be part of a cast. This is an exciting opportunity for students to use the skills they have learned in their theater and dance classes and apply them on a major scale. Come with a passionate sense of exploration, commitment and play. *Audition required; preference given to those who have completed THR202, THR404, THRO30 or THRO40 (or equivalent). All grade levels may participate. Provides 2/3 credit toward the studio/performance arts requirement. Students enrolled in THRO40 must also be enrolled in PEC109 for PE credit.*

PEC109: THEATER PRODUCTION WARMUP

This course is taken for PE credit in conjunction with enrollment in THRO20, THRO30 and THRO40. Theater Production Warmup meets the physical education requirement and will include vigorous activity that prepares students for production participation.

■ Public Speaking

THR203: PUBLIC SPEAKING

This course offers opportunities to practice speaking in community. Students experiment with writing, preparing and delivering effective and engaging speeches. While investigating communication strategies, students also explore somatic exercises to deepen their own physical and vocal awareness, and manage the anxiety that often accompanies public speaking. We emphasize attention to the dynamic relationship between speaker and audience, and students take an active role in each other's growth. Students offer one another constructive feedback and gain greater insight into their own public speaking goals. The encouraging and supportive environment fosters greater self-confidence while developing both empathy and leadership skills. *Provides one term of credit toward the studio/performance arts requirement.*

■ Film

THR206: FILMMAKING

This course provides practical experience in basic cinematography without dialogue. Using digital video equipment, students learn about the history of filmmaking as well as the use of the camera and editing techniques to create their own short films. Student, amateur and professional film sequences are discussed and analyzed. *Provides one term of credit toward the studio/performance arts requirement.*

Dance

■ Dance Technique (Physical Education Credit)

Technique classes meet three to four days per week for the duration of the physical education term, and students earn one physical education credit. They are open to all grade levels. Each class includes an extensive warmup, followed by center- and across-floor exercises and combinations. Technique, flexibility, strength, control, coordination and cardiovascular exercise, in addition to artistic expression, are stressed at all course levels. Each course level builds upon technical expertise gained in the previous level(s). New material is introduced each term so that a student may retake a course until technically ready to move into the next level.

Note: Students interested in or new to the dance program should contact the Director of Dance for level placement prior to registering for classes.

DAN100: INTRODUCTION TO DANCE

This course introduces students to three primary disciplines: ballet, modern and jazz. Basic composition and improvisation skills will be introduced. Little or no previous dance training required. *Offered: fall and winter terms.*

DAN200: INTERMEDIATE DANCE I

This course focuses on concert dance disciplines: ballet, modern and jazz. Composition and improvisation skills will be developed. Previous dance training, which must include ballet, is required. Students must supply their own ballet technique shoes. *Prerequisite: two terms of DAN100 (preferably in consecutive terms) or instructor permission.*

DAN250: INTERMEDIATE DANCE II

This course focuses on concert dance disciplines: ballet, modern and jazz. Composition and improvisation skills will be developed. Students must supply their own ballet technique shoes. *Prerequisite: at least one term of DAN200 or instructor permission. Previous dance training, which must include ballet, is required. Offered: fall and winter terms.*

DAN300: ADVANCED DANCE

This course focuses on concert dance disciplines: ballet, modern and jazz. Composition and improvisation skills will be developed. Students must supply their own ballet technique shoes. *Prerequisite: at least one term of DAN250 or instructor permission. Extensive dance training, which must include ballet, is required.*

DAN301: ADVANCED DANCE – INTENSIVE

This accelerated course provides advanced dancers with intensive training in concert dance disciplines (ballet, modern, contemporary and jazz). Classes will consist of a warmup, technique and complex choreographed phrases, along with composition and improvisation. *Prerequisite: instructor permission. Extensive dance training, which must include ballet, is required. Offered: fall and winter terms.*

DAN310: DANCE TECHNIQUE WARMUP

This course is taken in conjunction with DAN040. Dance technique warmup will include multigenre movement techniques. *Offered: spring term.*

■ Dance Study (Studio/Performing Arts Credit)

Note: A full credit toward the studio/performance arts requirements is awarded when a student has earned a total of one (or more) credits in theater and dance courses.

DAN010: SPECIAL STUDY IN DANCE

Special Study in Dance offers students a specialized learning experience to focus on a specific style of dance. In the lessons, students develop technique and expression, and explore the style's history and cultural significance. Students meet with an instructor for one hour per week at a mutually agreeable time for all students enrolled. Classes can occur during student free periods, weekday nights or weekends. One hour of homework/practice and one hour of class time is expected. In 2026-27, Special Study in Dance is offered

for pointe, and additional styles will be announced. *Permission from the Director of Dance is required. In certain cases, a placement class/audition may be required. Provides 1/3 credit per term toward the studio/performance arts requirement. Students normally receive 10 lessons per term. At least eight lessons are required to pass this course.*

DANO10: POINTE

Pointe dancing is a 200-year-old component of ballet that requires strength, skill and artistry. This course provides instruction in pointe for students in the form of one 50-minute class per week, with a class of four to 12 students at similar levels of technical proficiency. Class will consist of warm-up and strength-building exercises at the barre, followed by center floor combinations that focus on balance, traveling steps and turns. Advanced pointe dancers will learn classical variations and contemporary repertoire. *Permission from the director of dance is required. Students must be simultaneously enrolled in a dance technique class for PE credit (DAN250, DAN300 or DAN301). Provides 1/3 credit per term toward the studio/performance arts requirement; credit is granted upon completion of three terms of study. Students normally receive 10 lessons per term. At least eight lessons are required to pass this course.*

■ Dance Performance (Studio/Performing Arts Credit)

Note: A full credit toward the studio/performance arts requirements is awarded when a student has earned a total of one (or more) credits in theater and dance courses.

DANO20: DANCE COMPANY

Fall and winter dance companies produce a concert centered around a theme, featuring choreography by faculty, guest artists and students. DAN020 is a two-term commitment. In the fall term, students will follow a curriculum that explores dance composition, technical theater concepts for dancers and other

workshops. Students may apply to choreograph an original piece and collaborate with faculty lighting, sound, scenic and costume designers. Choreographers will begin this work in the fall term and perform works in progress at the end of the fall. Rehearsals will continue in the winter term and will conclude with a fully produced dance concert. In addition to four days per week of intermediate or advanced-level technique classes (M, T, Th, F), DAN020 includes two days per week (Wednesdays and Saturdays) for choreography rehearsals, tech rehearsals and/or performances. *Prerequisite: Students currently enrolled in DAN300 or DAN301 are eligible with instructor permission. Provides 1/3 credit per term toward the studio/performance arts requirement. Offered: fall and winter terms. Students must enroll in both terms unless special permission from the instructor is granted.*

DANO40: DANCE CONCERT ENSEMBLE

The Spring Dance Concert Ensemble produces a two-hour mainstage concert featuring original choreography by faculty, guest artists and students, centered around a theme. Students may apply to choreograph an original piece and collaborate with faculty lighting, sound, scenic and costume designers. Intermediate and advanced-level dancers work collaboratively and perform a range of disciplines that may include contemporary, ballet, modern, jazz, hip-hop and dances/rhythms of the African diaspora. Rehearsals are held six days per week. *Prerequisite: DAN200 or higher; instructor permission required. Students enrolled in DAN040 must also be enrolled in DAN310 for PE credit. Provides 2/3 credit per term toward the studio/performance arts requirement. Offered: spring term.*

Transition Courses

SSK100: STUDY SKILLS

Ninth and 10th graders new to Phillips Exeter Academy may be recommended for this one-term course on the basis of their academic performance during fall term and the advice of their adviser and of the academic advising committee. The major objectives of this course are to learn more efficient study methods, to develop time management techniques, to anticipate what teachers will deem most important in courses, and to efficiently meet those goals. This course

counts as one of the student's five courses and provides one term credit. The course, which is not a study hall, makes use of a variety of materials and texts and also provides students with an opportunity to focus more closely on the demands and homework of their other courses. Coursework is graded as P (pass) or NP (no pass). *Open to 9th and 10th graders new to PEA with permission from the Dean of Academic Affairs. Offered: winter term.*

Special On-Campus Offerings

FIELD COURSES (999s)

Qualified students who have exhausted the related course offerings in a particular discipline may petition to add a field course as part of their program. Field courses involve advanced and, in appropriate measure, independent study in a field of special interest and competence. Such work earns one credit per term. Field courses are graded and generally meet in a regularly scheduled format. Students must petition the dean of faculty and the chair of the academic department in which the course would be offered. The petition requires a course content proposal and a series of approval signatures from the instructor, the student's academic adviser and the department chair. Seniors should consult with their college counselors. Field courses are approved only when petitioning students have persuaded the chair and the dean of faculty that their field course promises desirable educational results that the existing curriculum might not provide. A department and the dean of faculty both reserve the right to approve or deny any field course proposal; staffing and/or workload constraints or other considerations may override the worthiness of a particular petition. Petitions for field courses must be submitted by midterm of the term preceding the desired course placement.

SENIOR PROJECTS

The faculty affirms its belief that education takes place outside as well as within traditional classrooms. Thus, seniors may design individual or joint projects of comparable value and scope to those of an academic course. If such learning replaces formal instruction, however, it requires the same kind of preparation, evaluation, support and supervision that classes demand. For this reason, instructors will ordinarily be advisers for no more than one project per year. Seniors may take only one project during the year.

Projects are approved only when petitioning students have persuaded the faculty that their projects promise desirable educational results that traditional instruction might not provide. Although projects are student-initiated, they are not approved as a matter of right, but remain subject to the educational control of the faculty. In general, one-year seniors are not eligible.

Approval and completion of Senior Projects are governed by the following understandings:

- › In one term only (fall, winter or spring) a senior may request to substitute one project for one formal course.
- › Projects are graded on a pass/fail basis and provide one academic credit, but may not be substituted for a course required for the diploma.

- › Project advisers will write a comment for the student's report at the end of the term.
- › Students must design their own projects and present a clear statement of goals in a proposal and submit a senior project application form. Students must also secure the written approval of their academic advisers, project advisers and college counselors. If the project falls within the jurisdiction of an academic department, it requires the approval of the full department and the heads of academic departments; if outside, it first requires the approval of the heads of any involved departments and then the heads of all academic departments.

Students must observe the following schedule:

- › Every senior who intends to propose a project must meet with the Dean of Academic Affairs to begin the approval process.
- › A senior proposing a project outside of a department should see the Dean of Academic Affairs as early as possible.
- › By the end of the second week of the term preceding the project term, a senior must submit the final written proposal through the Formsite link provided by the Dean of Academic Affairs.
- › Students with approved projects must meet for conferences with project advisers at least one format per week throughout the term.
- › Students are required to present the final results of the project in some tangible form, such as a written report, reflective essay, lesson plan, journal, portfolio, video, public performance or exhibition. Students have the option to submit a record of the project to the Academy's archives by completing the Archive Transfer form and the Special Collections Deed of Gift form. A schedule of all presentations will be distributed.
- › At the end of the term, students will make summary presentations of their work to members of the community in a public showing of Senior Projects.

Special Off-Campus Offerings

Applicants should ascertain that their time off campus will not jeopardize the fulfillment of the regular requirements for the diploma. Particular attention must be paid to the diploma requirements in English; Modern and Classical Languages; History; Mathematics; Religion, Ethics and Philosophy; and Science. Students should carefully read the program description for the offering to determine if a term credit in physical education or any additional credits will be granted. Day students who are selected to participate in off-campus programs become boarding students for that term and must pay the boarding tuition for that term. Most programs also include a surcharge to reflect the higher cost of the program. Students should carefully read the program description for the offering to find out about surcharges.

Specific dorm or room assignments cannot be guaranteed for students returning from off-campus programs, and students leaving for programs during the year must vacate their rooms and make them available to other students returning to campus. Students studying domestically or abroad on a program may not return to campus during the term they are away. Students on financial aid do not pay more to attend any of the off-campus term or year-long programs. Any surcharges are included in the determination of the grant. For the Exeter-designed programs, financial aid is available and calculated through the regular need-based financial aid process. For the three external programs in which we participate (Mountain School, School Year Abroad and Island School), Exeter's financial aid office works with the financial aid office of the external program to calculate a combined financial aid grant. In addition to completing the financial aid application process for Exeter, financial aid recipients will need to complete the financial aid application process with each partner school or program as well. The programs are competitive, and admission is not guaranteed. The availability of some of these programs is dependent upon sufficient enrollment and the staffing needs of the Academy. The Washington Intern Program and Winter Term in Spain both require a minimum of eight participants in order to run. Participants must satisfy the residency requirement of attendance on campus at Exeter for at least three terms during their upper and senior years.

FALL OR SPRING TERM AT THE MOUNTAIN SCHOOL, VERSHIRE, VERMONT

Exeter participates in the fall and spring semesters of The Mountain School of Milton Academy. The program offers uppers (and occasionally seniors) the opportunity to enjoy a different living and

learning experience, while at the same time retaining a rigorous college-preparatory academic schedule. The school is located on a 300-acre farm in eastern Vermont and is intimate in size — 45 students and 12 faculty members. The purpose of the program is to provide students with a new understanding of their relationship with the natural world and the responsibility this relationship creates through their studies; their work on the farm and in the forest; and their day-to-day life in rural New England. Due to the end date for the Mountain School fall semester, fall students will return to PEA in January and will be expected to catch up with missed material but not to submit tests, quizzes or papers issued during their absence. Students departing for Mountain School spring semester will be enrolled in classes at Exeter until the midterm of winter term but will not receive academic credit for their winter term classes.

Students wishing to participate in the program must apply in January of the previous school year. Students will receive one English diploma credit and one physical education term credit, and depending on the courses they enroll in, they can earn diploma credit in U.S. history, mathematics, modern languages, classical languages, studio art or science. Students may be asked to take math and language placement tests upon their return. They should be in touch with the respective department chair(s) prior to returning to campus. Students who attend in the spring semester must make arrangements with the HHD Department to complete the HHD requirement in advance of their departure. There is a surcharge for the program.

SCHOOL YEAR ABROAD

School Year Abroad, founded in 1964, is a program sponsored by the three charter schools of Exeter, Andover and St. Paul's. In addition to these three charter schools, SYA's association includes a consortium of other top U.S. independent schools that have demonstrated a strong commitment to foreign and classical language instruction, as well as international education. Admission to these programs is competitive. The total enrollment in each program is about 60 students.

The programs in France and Spain are designed for students going into their upper or senior years who have completed two years of French or Spanish. The program in Italy is for students also going into their upper or senior years who wish to begin or continue the study of Latin or Italian. Each of these programs offers a full year of residence and study in the respective country.

The programs are conducted during the school year in Rennes (France), Viterbo (Italy) and Zaragoza (Spain). The courses have always been fully accredited by the three schools. The purpose of these programs is for students to participate in a full academic year, as well as to reap the benefits of living in a foreign culture

while achieving a level of real fluency or skills virtually impossible to attain at their home schools. Since some of Exeter's graduation requirements (e.g., Religion, Ethics and Philosophy and Science) cannot be fulfilled in Rennes, Viterbo or Zaragoza, interested students should develop as early as possible a long-range plan of studies that will assure their eligibility.

Participating students have their Exeter requirements reduced by a year, so a four-year student must complete the three-year Exeter graduation requirements plus the SYA year, or a three-year student must complete the two-year Exeter graduation requirements plus the SYA year. Students may be asked to take math and language placement tests upon their return. They should be in touch with the respective department chair(s) prior to returning to campus.

In each program, students live with host families and participate fully in their lives. They join athletic and cultural organizations with their French, Italian or Spanish counterparts and travel both on several school-sponsored trips and independently. Academically, each student pursues a minimum of five courses selected from a curriculum especially designed for School Year Abroad students. Standard upper and senior English and mathematics courses are taught in English, generally by teachers from the charter or member schools. Subjects such as literature, language, history, environmental science, civilization and art history are taught in the target language by native instructors. The classes are rigorous and reflect the standards of the sponsoring schools. Students are encouraged to participate in physical activities; however, they are exempt from the physical education requirement while participating in the program. All College Board Examinations are offered. More information may be found at www.sya.org.

The cost of the programs, including flight, is set by SYA and may differ from the cost of a year as a boarder at PEA. Financial aid students have their aid award increased to cover the SYA tuition differential. Catalogs and further information may be obtained from the Exeter SYA coordinator.

FALL TERM AT THE ISLAND SCHOOL, CAPE ELEUTHERA, BAHAMAS

Lowers and uppers are eligible to study at the Island School on the shores of Cape Eleuthera, Bahamas, for the fall semester. This rigorous program focuses on sustainability and experiential and environmental education. The 48 students, who constitute the program's student body each semester, come from different schools and live and study on the Island School campus. Students take courses in land and environmental art, literature of the sea, Bahamian history, math, marine ecology and research. Students also participate in scuba, daily morning exercise, kayaking trips, community service and island exploration. The Island School does not offer foreign language courses, and applicants are encouraged to speak with their advisers about the potential impact on their course of study. Admission to the program is competitive. See the PEA Island School program director for more information and visit www.islandschool.org. Applications are available at the Island School website and must be submitted to both the Island School and the PEA Island School program director by mid-February.

Due to the end date for the Island School fall semester, students may or may not return to Exeter in December, depending on the academic year calendar dates. If a student does not return until January, it is expected that the student will keep current with missed material but is not responsible for making up any tests, quizzes or papers that were issued during their absence in December.

Students will receive two diploma credits in the biological sciences and one diploma credit each in studio art, English and physical education for completion of the program. Students may be asked to take math and language placement tests upon their return. They should be in touch with the respective department chair(s) prior to returning to campus. There is a surcharge for the program. *Prerequisite: one year of biology.*

FALL TERM IN GRENOBLE, FRANCE

Students who have completed French 230 or higher may apply for a fall-term program for seniors in Grenoble. Students live with host families and take courses at a local high school, with offerings that may include French literature, history and geography, philosophy, science and math. The program includes a five-day trip to Paris, either at the start of the program or during the October break. Students also go on three or four local excursions during their stay. Students should plan to complete their standardized testing (ACT and SAT) prior to departure; there will not be an opportunity to take standardized tests while they are in Grenoble.

Students will receive two language diploma credits and one physical education diploma credit for completion of the program. A maximum of 12 students may participate. There is a surcharge for the program.

FALL TERM IN YOKOHAMA, JAPAN

Qualified students studying Japanese can choose to study in Yokohama, Japan, in the fall of their senior year. Students will live with host families and attend Toin High School. The school emphasizes the development of well-rounded individuals by encouraging critical thinking and creativity through interdisciplinary projects and inquiry-based learning; promoting environmental awareness and sustainability practices within the curriculum; and fostering social responsibility through community engagement and service-learning opportunities. Students will attend classes such as math, science, PE and art with Japanese students as well as specially designed classes for PEA students, such as Japanese language classes and Japanese society and history classes.

Students will receive two language diploma credits and one physical education diploma credit for completion of the program. Students should plan to complete their standardized testing (ACT and SAT) prior to departure. There is a surcharge for the program.

WINTER TERM IN GÖTTINGEN, GERMANY

Qualified seniors studying German may elect to study in Göttingen, Lower Saxony, Germany, during the winter term. Students attend the Theodor Heuss Gymnasium and carry a six-course load, including German language and literature and other subjects according to the student's interests. Involvement in sports and clubs is also expected.

Students live with German families and are integrated into everyday family life. The winter term in Göttingen begins shortly after January 1. Participants do not return to campus for the start of the PEA winter term, but will undertake a directed research project in preparation for their stay in Germany. Interested students should contact their German instructor in their upper year.

Students will receive two language diploma credits, one physical education diploma credit and one English diploma credit for completion of the program. There is a surcharge for the program.

WINTER TERM IN MADRID, SPAIN

Seniors who have completed two years of Spanish may apply to a winter term program in Madrid, Spain. Students will attend high school with students from Colegio Santa María la Blanca, where they will take courses that may include history, economics, philosophy, math and science. They will further study Spanish literature, grammar and culture taught by the program director, who is a faculty member from Phillips Exeter Academy.

The school and the host families are in a neighborhood called Montecarmelo in the north of Madrid. Courses will be complemented by field trips to Barcelona, Sevilla, Granada, Córdoba, Toledo, Salamanca and local museums and sites of interest such as el Museo del Prado, the Thyssen-Bornemisza museum and el Escorial. The winter term in Spain begins in early January.

Participants do not return to campus for the start of the PEA winter term but will undertake research in preparation for their stay in Madrid. Students will receive two language diploma credits and one

physical education diploma credit for completion of the program. There is a surcharge for the program.

SPRING TERM WASHINGTON INTERN PROGRAM

The Washington Intern Program, inaugurated in 1966, is open to qualified seniors. One-year seniors are not eligible to participate. Each student is assigned to the office of a United States senator or representative and works in that office during the day. Though the initial work tends to be clerical, interns often assist their offices in other ways, including answering constituent mail, researching legislative fact sheets, writing drafts of speeches, and reporting business conducted at hearings. They are also given time by their offices to observe the various branches of government in operation. In addition, seminars arranged by the director of the program bring interns together with prominent Washingtonians of various professions and divergent political philosophies. Speakers, about 12 in number, include members of the administration, judges, lobbyists, and officers of regulatory agencies. Interns live in Washington. The director of the program is in residence.

Students may elect to enroll in an English seminar in Political Literature and American Culture in order to receive English diploma credit. Students taking U.S. history in senior year may apply and will be expected to undertake a course of study and a research project using available Washington, D.C., resources in order to receive diploma credit for U.S. history. The program begins following spring break and ends the week before graduation. Students who participate in the Washington Intern Program are not able to take Advanced Placement exams in May. There is a surcharge for the program.

Advanced Placement Program

College Board's Advanced Placement (AP) program certifies college-level work undertaken by students in secondary schools. Exeter does not subscribe to the AP program, but many courses at Exeter are taught at or beyond the AP level and are sufficient preparation for AP exams; Exeter administers the AP exams on campus each May. AP exams are scored from 1–5, and there are several advantages to scoring a 4 or 5, including earning college credit or receiving an exemption from college distribution requirements or lower-level requirements in specific disciplines. (Students and families should consult prospective colleges about their "Advanced Standing" policies with regard to high scores on the AP exams. College Board also provides an AP Credit Policy Search tool at apstudents.collegeboard.org/getting-credit-placement/search-policies.) Only students with consistently superior academic

performance in a specific subject area should consider taking AP exams or taking multiple exams during the same testing period. Furthermore, 9th and 10th graders should not take AP exams unless their Exeter coursework aligns with a specific AP exam; 11th graders should test only in disciplines in which they will have completed study prior to 12th grade (e.g., biology, chemistry, physics, math).

In general, all students should consult with their adviser, subject area teacher and the College Counseling Office prior to registering for standardized tests. AP exams are not required for admission to domestic colleges and universities; however, AP exams may be required for admission to international universities. The College Counseling Office continues to talk with college admissions partners (both domestically and internationally) about standardized testing.

NCAA and English Requirements

NATIONAL COLLEGIATE ATHLETIC ASSOCIATION (NCAA)

To participate in NCAA Division I or II athletics, you must meet certain academic eligibility standards. To be eligible to practice, compete and receive an athletics scholarship in your first year of full-time enrollment, you must earn 16 NCAA-approved core-course credits in the following five areas: English, math, science, social science and “world language, comparative religion or philosophy.” Both Division I and II eligibility require four years of high school English, and the number of credits required in each of the other areas differs by division. For more information, please visit www.ncaa.org/sports/2021/2/8/student-athletes-future.aspx.

It is important to note that not all Exeter courses are approved by the NCAA Eligibility Center as core-course credits. Students must be familiar with these requirements early in their high school careers so that the appropriate course of study can be planned. In addition, for the University of California system and other state colleges and universities, students must understand the specific state’s definition of minimum curricular requirements and how they are related to Exeter’s course offerings.

Below is a list of Phillips Exeter Academy courses that are NCAA-approved in each area, as of January 2026:

- › English: all PEA English courses
- › Math: all PEA math courses
- › Science: all PEA science courses (not including computer science)
- › Social science: all PEA anthropology, economics, psychology and history courses
 - Also approved are EXI306, EXI513 and the following INT courses: 503, 504, 508, 515, 519, 552, 553, 585
- › World language, comparative religion or philosophy:
 - All PEA classical languages courses
 - All PEA modern languages and cultures courses
 - All PEA REP courses except REL290 and REL590 (approval will depend on selected topic)

A current list of all Phillips Exeter Academy courses certified by the NCAA Eligibility Center is available at www.eligibilitycenter.org. To check whether specific courses offered at Phillips Exeter Academy are certified to meet NCAA requirements, you must use the school CEEB code 300185. Courses offered through off-campus programs must be certified through that particular program.

To check certification of individual programs, students may find the following information helpful:

YEARLONG OR SEMESTER PROGRAMS

THE MOUNTAIN SCHOOL: Vershire Center, Vermont	CEEB 460464
SCHOOL YEAR ABROAD: Rennes, France	CEEB 731845
Viterbo, Italy	CEEB 748646
Zaragoza, Spain	CEEB 792150

FALL TERM PROGRAMS

CAPE ELEUTHERA, BAHAMAS: The Island School through The Lawrenceville School	CEEB 310681
---	-------------

GRENOBLE, FRANCE:
UIAD is not registered with the NCAA

YOKOHAMA, JAPAN:
Toin High School
is not registered with the NCAA

WINTER TERM PROGRAMS

GÖTTINGEN, GERMANY:
Theodor Heuss Gymnasium
is not registered with the NCAA

MADRID, SPAIN:
Colegio Santa Maria la Blanca
is not registered with the NCAA

SPRING TERM PROGRAMS

WASHINGTON INTERN PROGRAM:
English course is NCAA-certified

ENGLISH REQUIREMENTS

Students who are planning to play Division I or II college athletics may need to take a third term of English (or two English electives in a single term if participating in an off-campus program) in their senior year in order to meet the NCAA four-year English requirement. Many public — as well as more and more private — colleges/universities also require four full years of English. Please refer to individual program requirements for further details.

Please direct any questions about NCAA certification to the student’s adviser, student’s coach, the Director of Studies or to the College Counseling Office.



